

Temporary Facilities and Construction Site Safety



Construction Sites



- Construction sites must provide a continuous, safe, accessible path of travel
- Avoid displacing pedestrians

Temporary Construction

- An alternate route should be provided whenever the pedestrian access route is blocked
- Warning signs shall be provided when an alternate circulation path is provided or a barricade is constructed
- Temporary facilities in the public right-of-way must conform to the requirements for permanent facilities

Construction Site Dangers



- Access to curb ramps and accessible alternative routes not provided
- Pedestrians forced to take circuitous or dangerous alternative routes

Construction Site Dangers

Pedestrian zone reduced or blocked by materials or equipment



Construction Site Dangers



- Ineffective barriers (plastic tape) around the site
- Fails to provide detection around site

Barriers

- Accessible barricades should be provided when construction occurs in the public right-of-way
- Barriers defining the alternate route should:
 - Be a minimum of 36-42 inches in height and continuous with the ground surface
 - Extend around the entire perimeter of the construction site or entire length of the alternate circulation route

Provide Effective Accessible Barriers



Solid and continuous, 36-42 inches high

Extend Barrier Around Entire Area of Construction



Barriers



This barrier does not provide adequate warning and rerouting signs

Barricades for Cane Detection

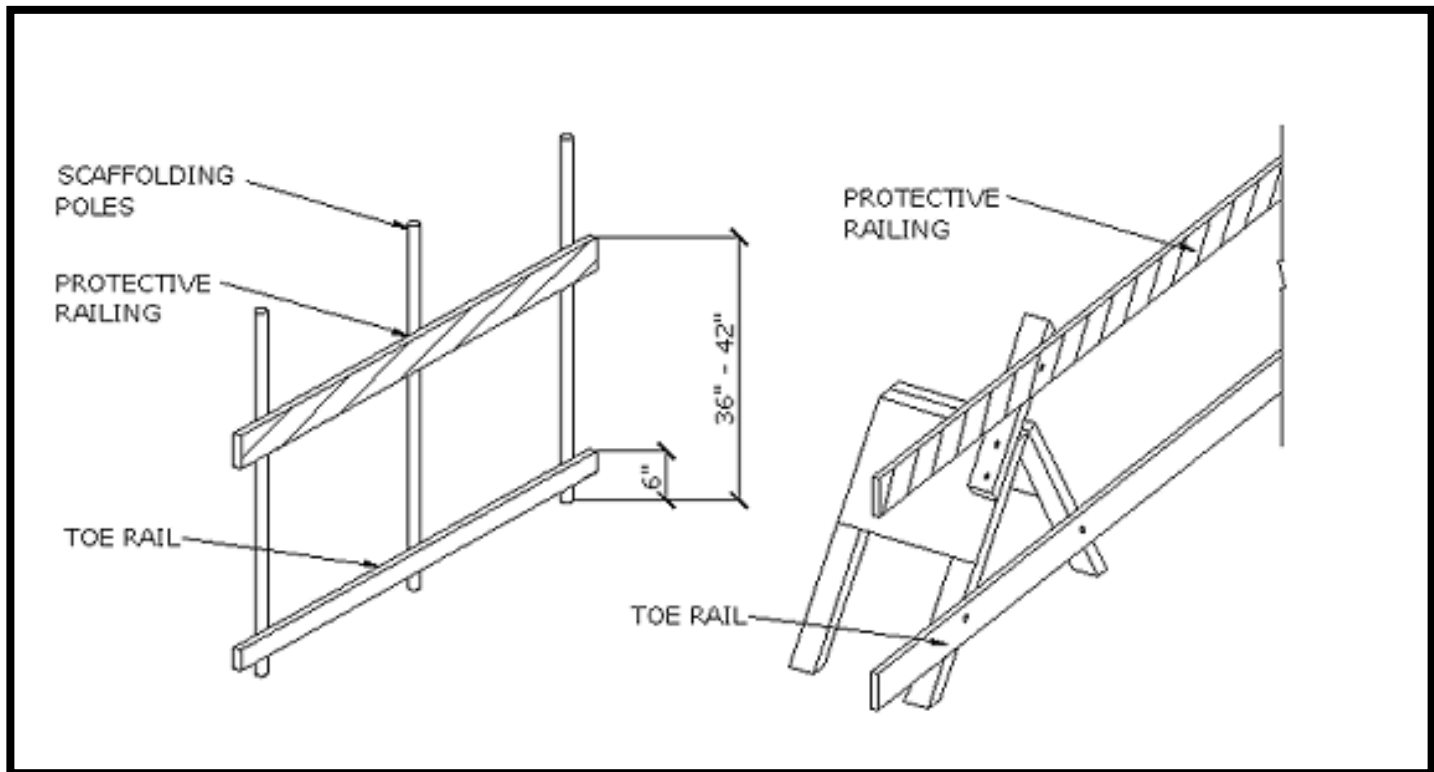

Curb Ramp Barricade for Cane Detection

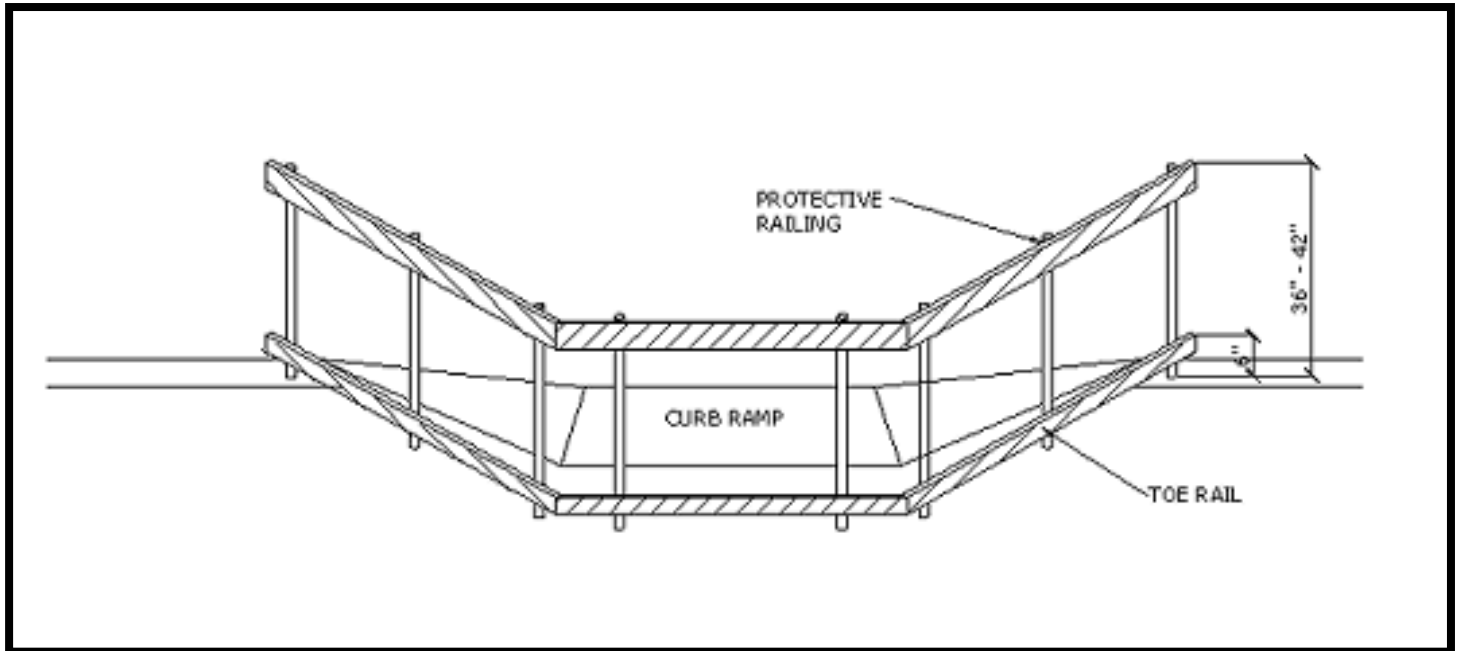

Effective method of providing information on crosswalk closing

Design Solutions



Turn protruding blocks and make them visible

Design Solutions



Temporary ramps and boardwalks ensure smooth continuous surface

Design Solutions



- Repair utility work as soon as possible
- Hold companies accountable for timely repairs

Design Solutions



Provide smooth patching to utility work

Design Solutions



Provide temporary curb ramps where needed

Design Solutions



Handrails Should Not Protrude into the Pedestrian Route (Must comply with ADAAG)

Design Solutions



Provide crash resistant barriers when a temporary pedestrian route is in the roadway

**Stairs Are
Part of the
Pedestrian
Zone**



Elevators and Lifts Should Remain Unlocked and Operable During Operating Hours

