



Sensitivity Testing of Activity-Based Models

TRB Innovation in Travel Analysis and Planning
Indianapolis, Indiana - June 5, 2023
MWCOCG TFS Meeting – July 21, 2023

Presented by Andrew Rohne



Introduction

- Testing of model scenarios during implementation of activity-based models (ABM)
- MPOs Covered in this Presentation
 - Metropolitan Washington COG (MWCOCG)—Washington, DC
 - Metropolitan Council—Minneapolis-St. Paul, Minnesota
 - Southeast Michigan COG (SEMCOG)—Detroit, Michigan
- Why Conduct Sensitivity Testing?
 - Testing fidelity of these models
 - Testing and calibrating sensitivity of the model
 - Understanding the model
 - Model training
 - Testing model features



General Test Logistics

- Test mid-late in calibration
 - Calibrate sensitivity of the model
- Test needs to be specific A-B test
 - “A” is the base scenario
 - “B” is limited changes to that base scenario
- Documentation and discussion is critical
 - Test methods – “what, why, how”
 - Comparison of expected outcomes (vague) and model outcomes (specific)
 - Discussion of impact—Is the model response “in the range of expectation”?

Model Status

	SEMOG	MWCOG	Metropolitan Council
Platform	TransCAD + ActivitySim	Cube + ActivitySim	Cube + ActivitySim
Status	Model Completed Some testing remains	Phase 2 (full calibration) nearing completion	Phase 2 starting soon
	First ABM	First ABM	Replacement ABM
	4.8 million people 2,811 TAZ/28,637 MAZ 4,600 square mi	7.2 million people 3,669 zones (internal) 6,800 square mi	3.6 million people 3,030 zones (internal) 10,190 square mi

Sensitivity Tests

	MWCOG Phase 1	Metropolitan Council Phase 1	SEMCOG
Behavioral	Telecommute Frequency Auto Operating Cost Toll Rates	Telecommute Frequency Auto Operating Cost TNC Pricing	Household Income
Network	Bridge Closure Transit Frequency	New Transit Service	New Transit Service

Telecommute Frequency Sensitivity Tests

Region	MWCOG	Metropolitan Council
Test	Increased telecommute for workers who work in DC by 50%	Increased telecommute regionally by a factor of 2
Key Results	25% fewer DC workers with Mandatory Pattern Slight VMT decrease 14% transit boarding decrease	6% fewer workers with mandatory pattern 2.6% VMT decrease 7% decrease in transit trip mode
Unexpected results	Noticed “bounceback” – number of DC workers increased from iteration to iteration - Fixed in Phase 2 using work location simulation constraint	
Notes	Behavior based on pre-pandemic data	

Auto Operating Cost Sensitivity Tests

Region	MWCOG	Metropolitan Council
Test	+ \$0.10 per mile	+ \$0.10 per mile
Key Results	Insignificant tour frequency change 6% transit trip increase 4% non-motorized trip increase	Insignificant tour frequency change 11% transit trip increase 12% non-motorized trip increase
Comparison	Higher transit adoption compared to MSP (6.4% observed tour mode choice transit share) Lots of zero-car HHs <i>by choice</i> in DC	Lower transit adoption compared to DC (3.9% of tours) 2% fewer zero-car households compared to DC

MWCOG Toll Rates Test

Increased AM peak period toll rates by 50% on variably-priced facilities

- I-95: Reversible Express Lanes
- I-495: Express Lanes both directions
- I-395: Reversible Express Lanes



MWCOG Toll Rates Test Results

Expected Change	Model Changes
Tour departures shift from peak to off-peak	<u>Slight</u> change from AM and NT to MD and PM
Mode shift – decrease SOV, increase SR3+	Slight shift from SOV and SR2 to SR3+ Slight reduction in walk and KNR transit
Shift away from toll facilities	Significant decrease in traffic on all toll facilities Significant increase on I-495 general-purpose lanes
Increased transit trips	Increased transit for two submodes (Comm Rail boardings +0.3%, Bus boardings +0.6%) Decreased transit boardings on Metrorail (-0.4%)

How Sensitivity Test Results Influenced Phase 2

- Phase 1 Model: Very muted time-of-day response to toll increases
- Phase 1 Model: Similar muted responses when testing overall AM congestion increase
- Adjusted mode choice logsum coefficients in time-of-day choice model in order to increase model response to congestion

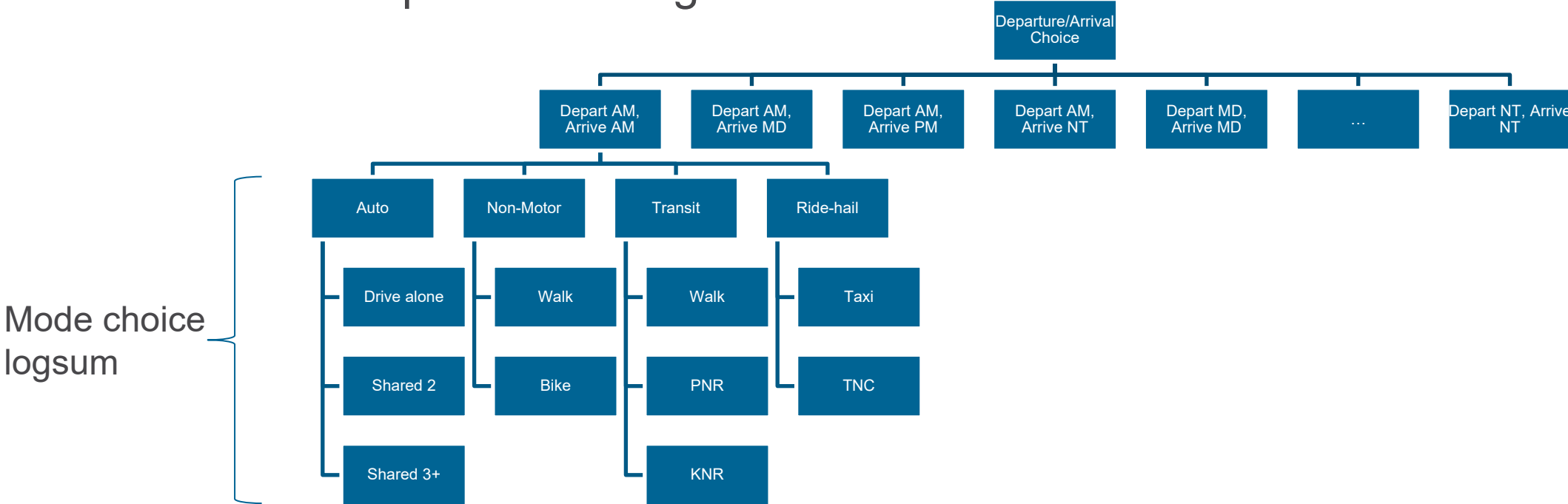

MWCOG Toll Rates Test Changes in Phase 2

Updated Tour TOD Choice

VMT by Time Period

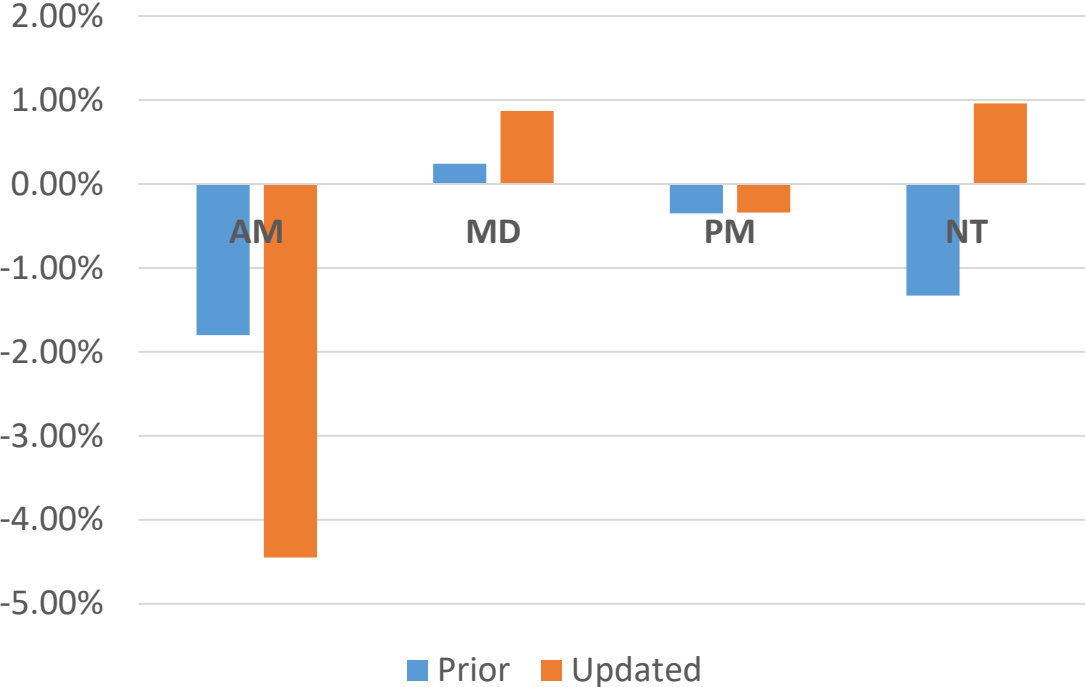

VHD by Time Period

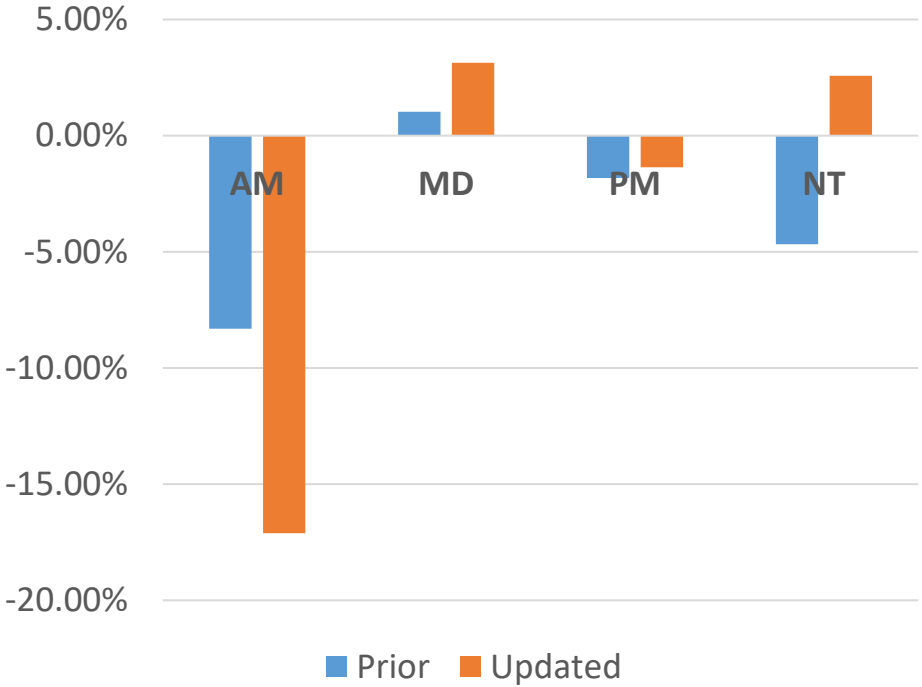

Metropolitan Council TNC Pricing Test

Subsidized TNC fare for lowest income group by 75%
(Household income < \$20,000 per year)

Expected Change	Model Changes
Increase in TNC trips	34% increase in rideshare trips
Decrease in transit trips	2% decrease in transit trips

SEMCOG Household Income Test

Adjusted household incomes for homes along Woodward Ave

- Streetcar Transit Corridor
- Four income scenarios tested:
 - +/- 50%
 - +/- 25%

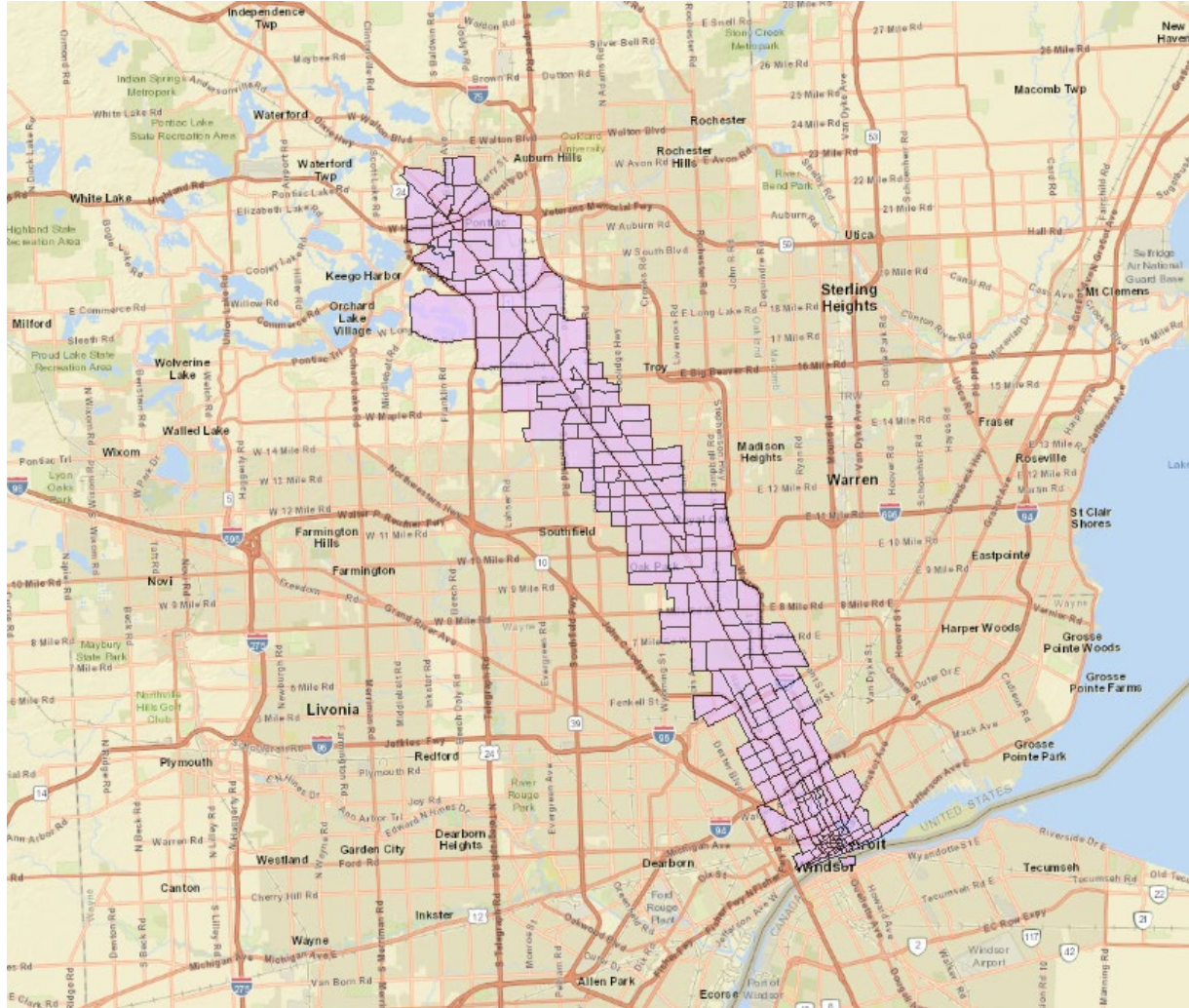

SEMCOG Household Income Test Results

Model Changes in Corridor

Increased Auto Ownership as income increased

Increased tours as income increased

Auto tours increased as income increased, transit tours decreased as income increased

Auto Ownership Changes



Tours by Purpose

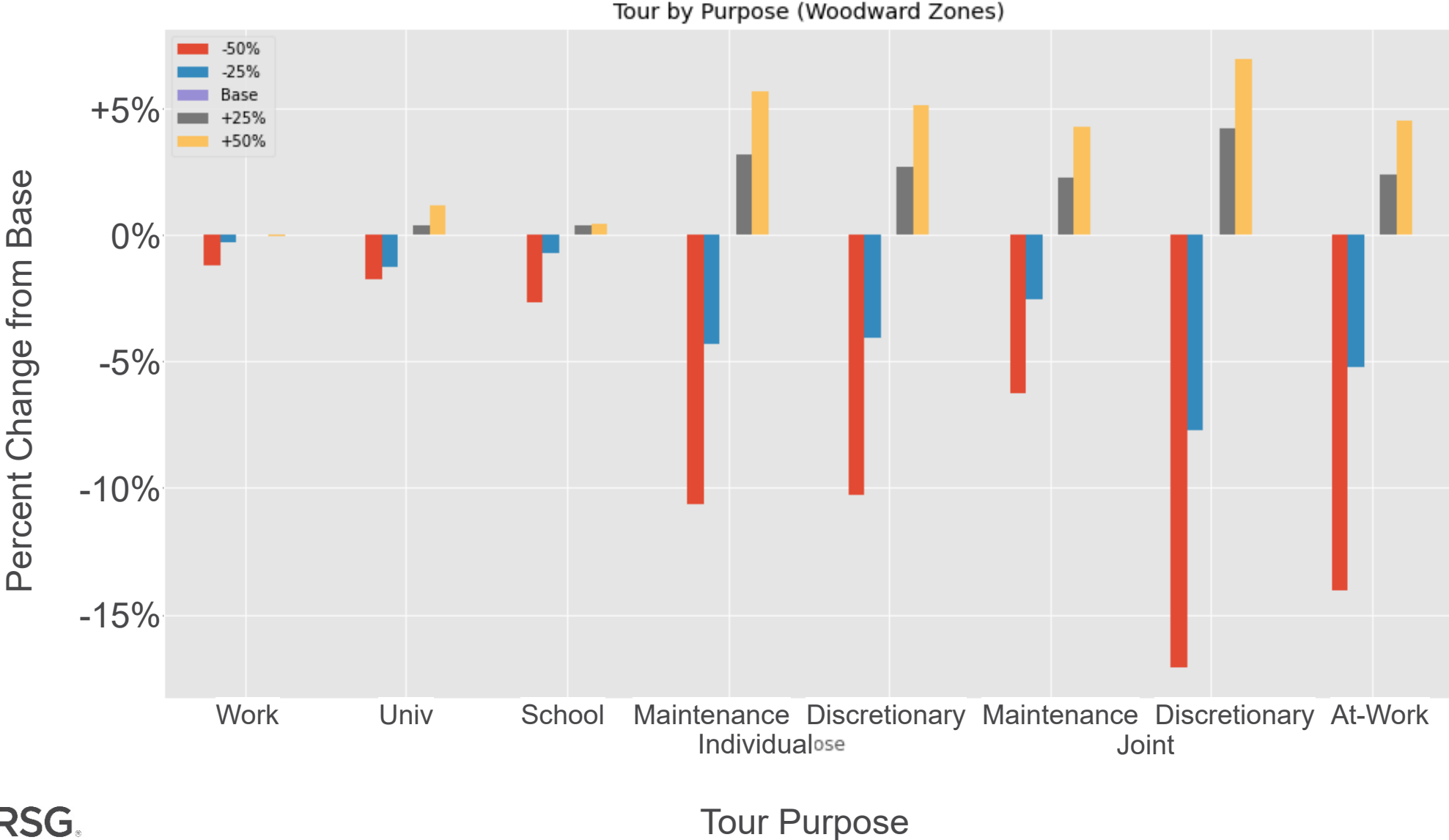

Tours by Mode

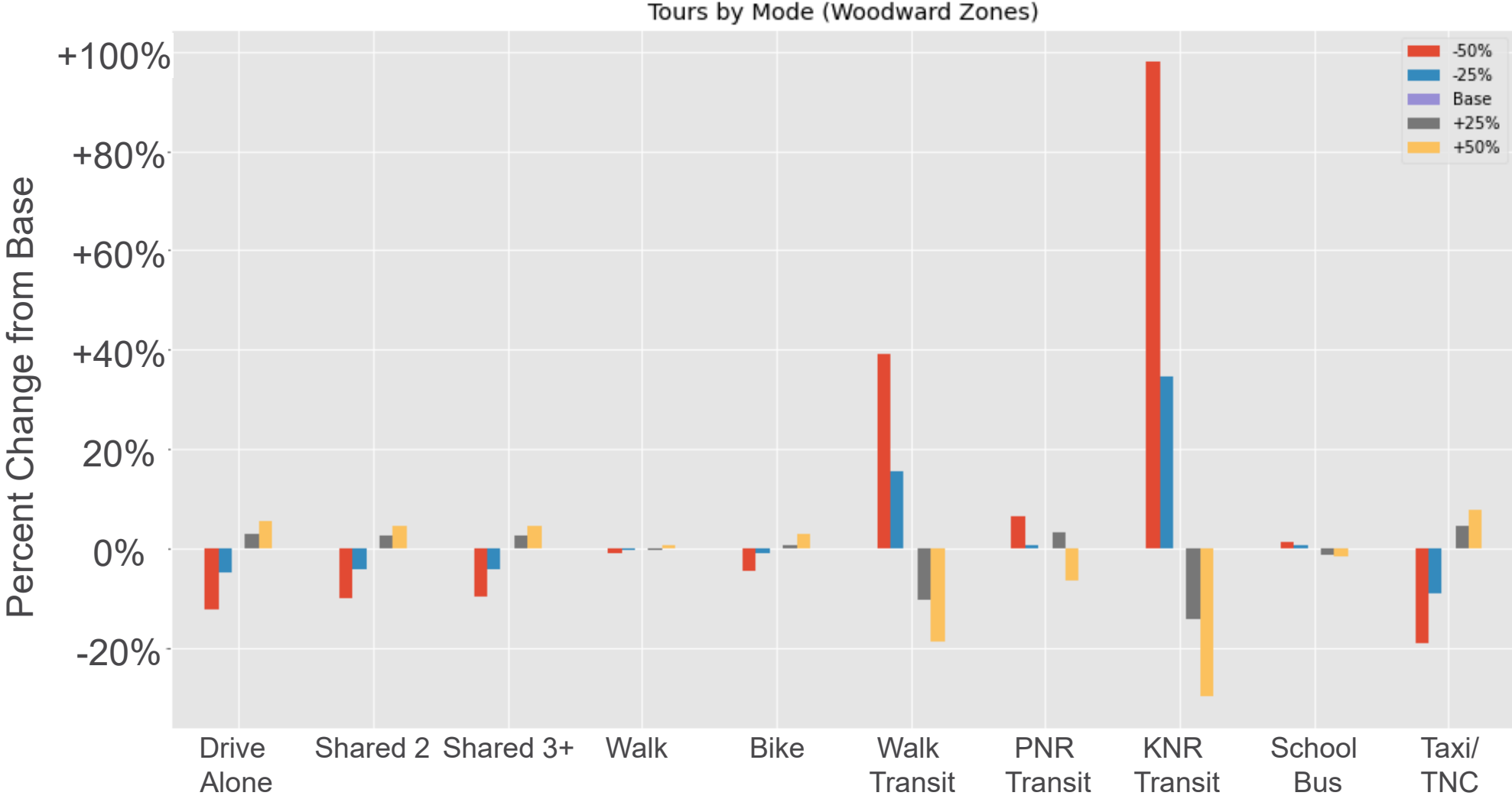

MWCOG Bridge Closure

- Closed the Arlington Memorial Bridge to auto and truck traffic
- Bridge remained open for transit and non-motorized modes

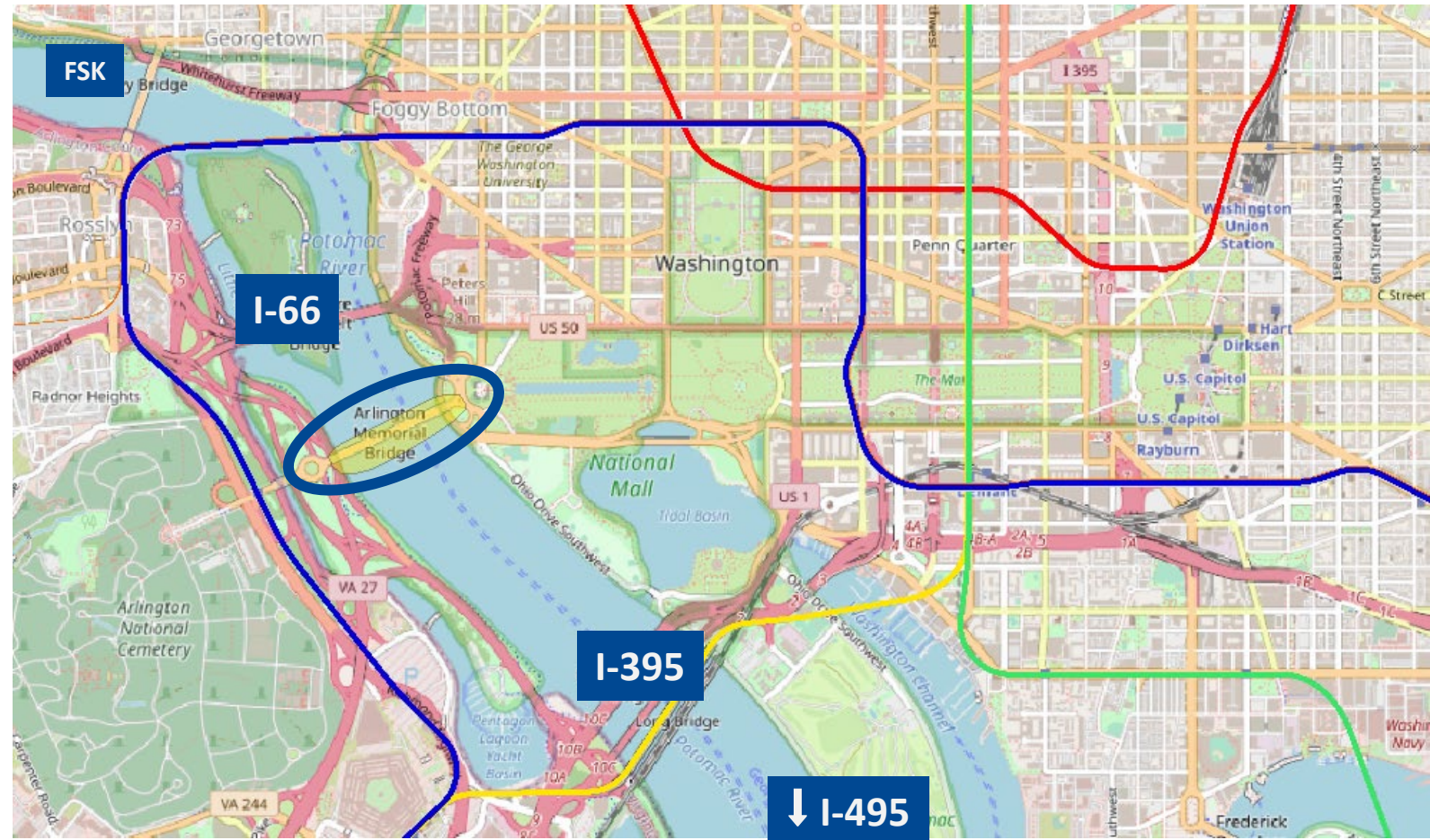

MWCOG Bridge Closure Test Results

Expected Change	Model Changes
Decrease in county flows that cross bridge	-2% to -3% for jurisdictions west of DC -3.5% reduction in autos between DC and N. VA
Slightly shorter tour lengths	Slightly shorter tour lengths regionally
Increase in traffic on other bridges	Large increases on I-66 and I-395, smaller increase on Francis Scott Key and I-495 (south)
Decrease in VMT or VHT, increase in VHD	0.07% reduction in VMT 0.01% reduction in VHT 0.12% increase in VHD
Increase in transit use	0.5% increase in transit

MWCOG Transit Frequency Test

Doubled Transit Frequency for high-capacity transit

- Metrorail
- Commuter Rail (MARC and VRE)
- Streetcar

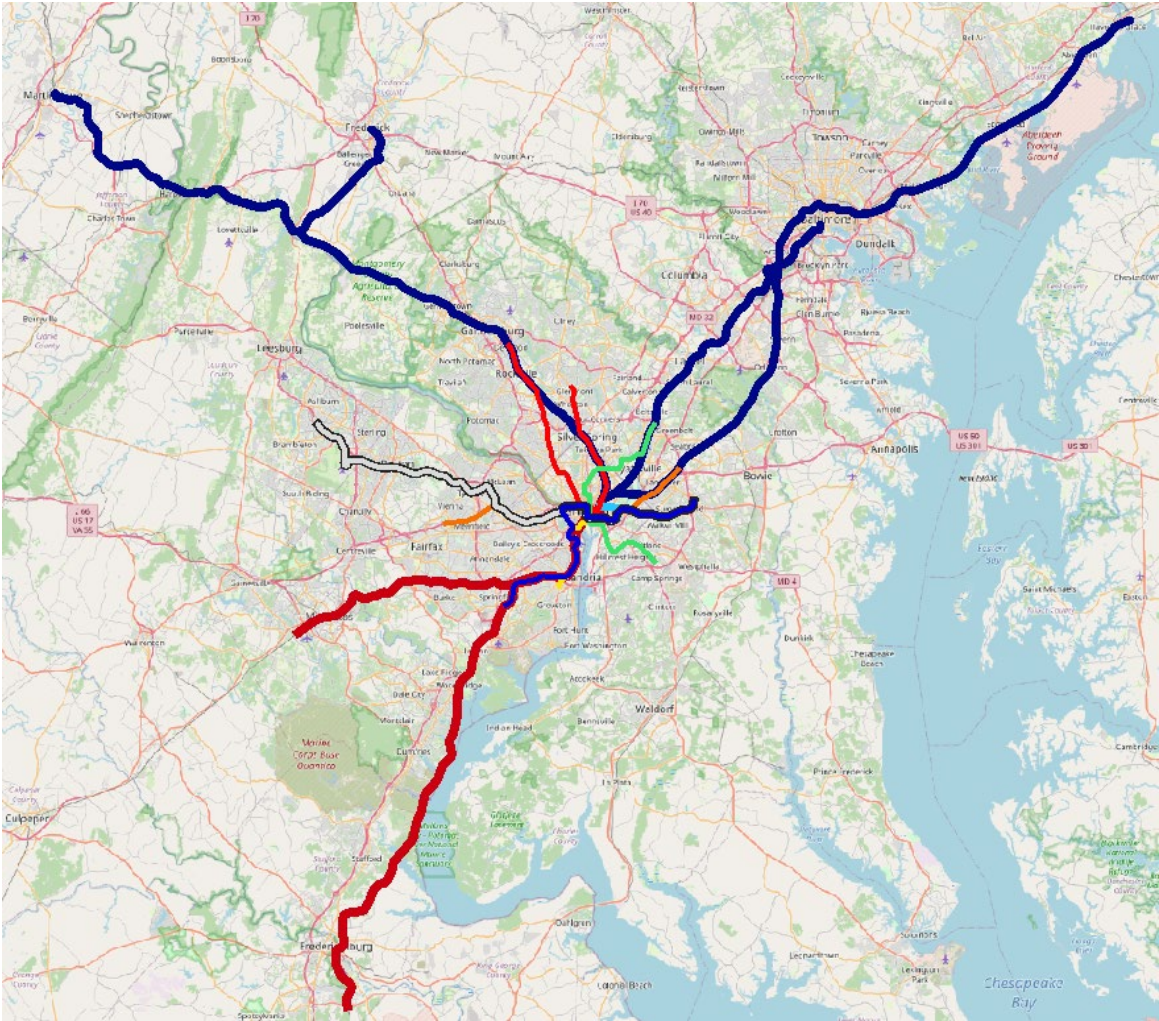
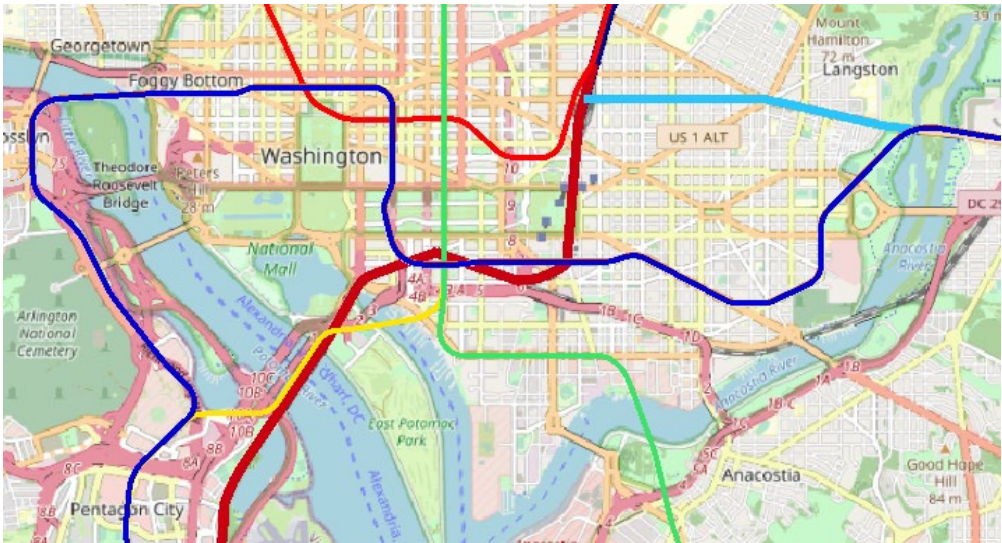

MWCOG Transit Frequency Test Results

Expected Change	Model Changes
More 0-auto HHs	+2% 0-auto
Decrease in VMT, VHT, VHD	0.3% less VMT 1% less VHT 2% less VHD
Increased transit boardings on rail, fewer boardings on bus	10% increase Metrorail boardings 50% increase commuter rail boardings 2% decrease bus boardings 6% transit increase overall

Metropolitan Council Transit Service Test

- Added Metro F Line rapid bus
- Added Green Line Extension from Target Field to Eden Prairie

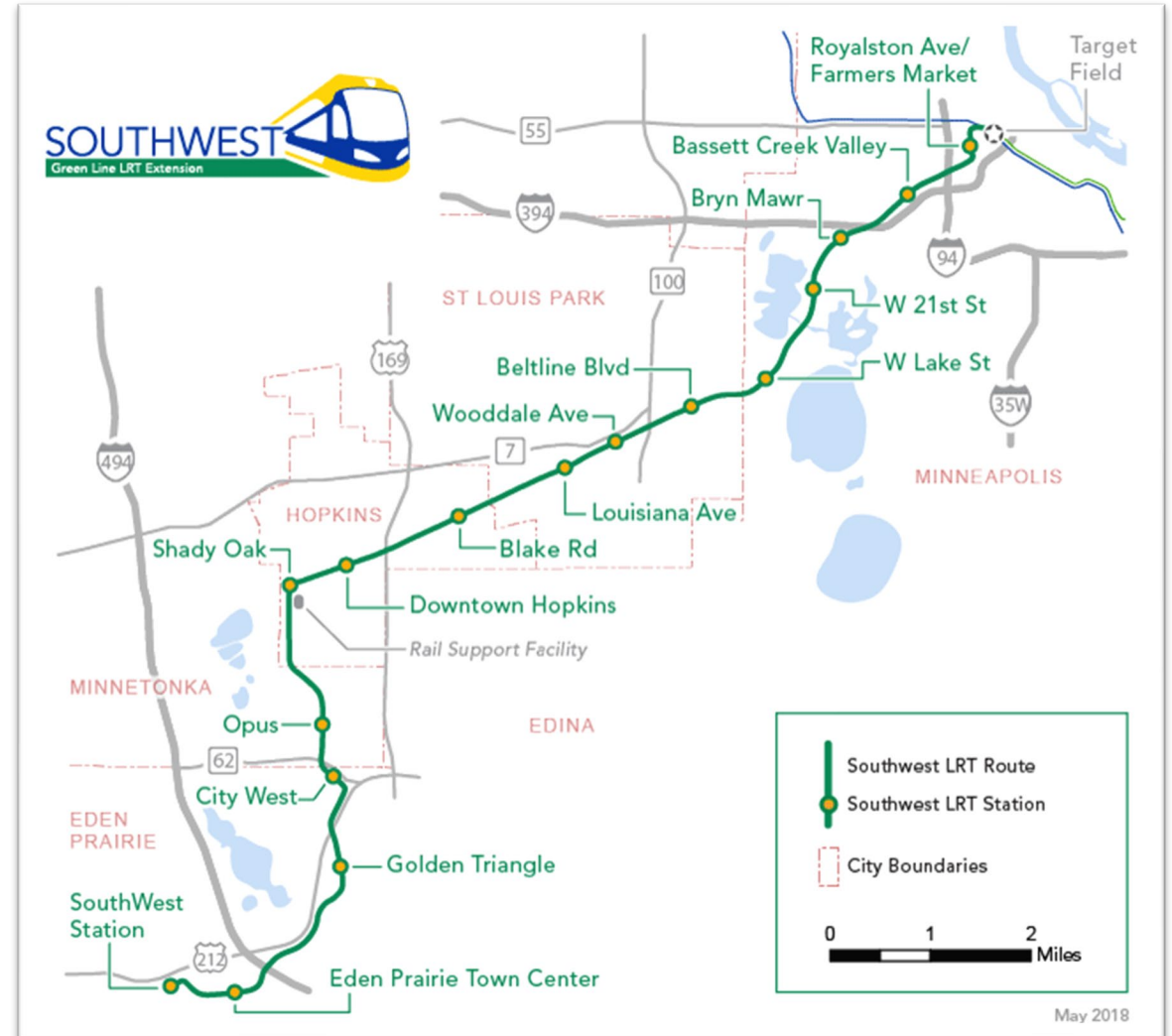
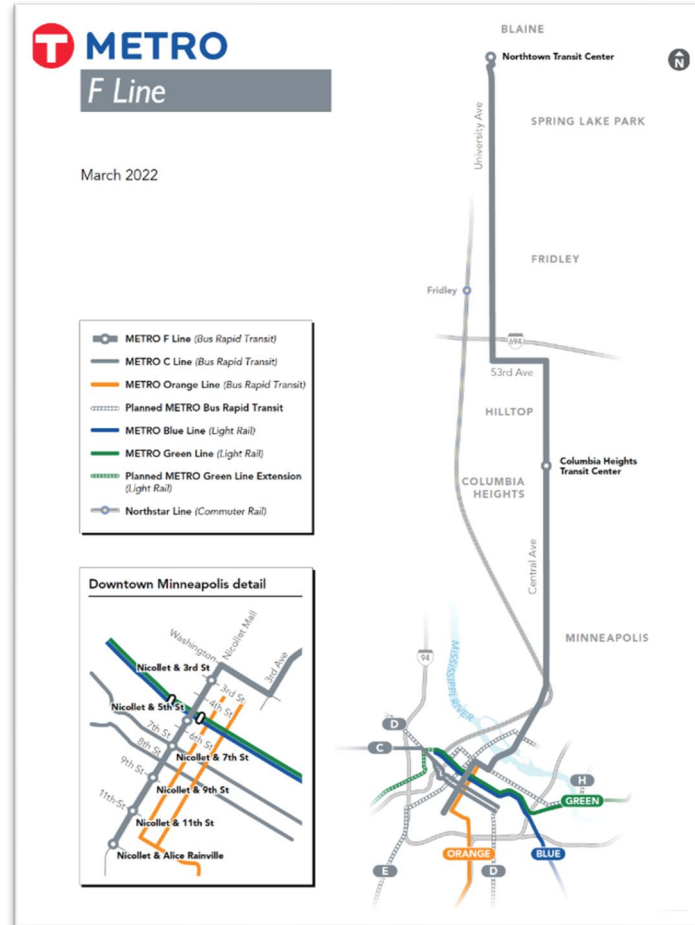

Metropolitan Council Transit Service Test Results

Expected Change	Model Changes
Decrease in VMT and auto trips	Slight decrease in VMT
Increase in transit trips	Slight increase in regional transit
Increased boardings in corridor	31% increase on Central Avenue Corridor (Route 10 + F Line / North) 17% increase on Green Line Corridor

SEMCOG Commuter Rail Test

- Added rail from Detroit to Ann Arbor
- 40-mile route, six stations
- 1 hour peak headways,
4-hour off-peak headways
- \$1 per station fare (\$5 for full trip)

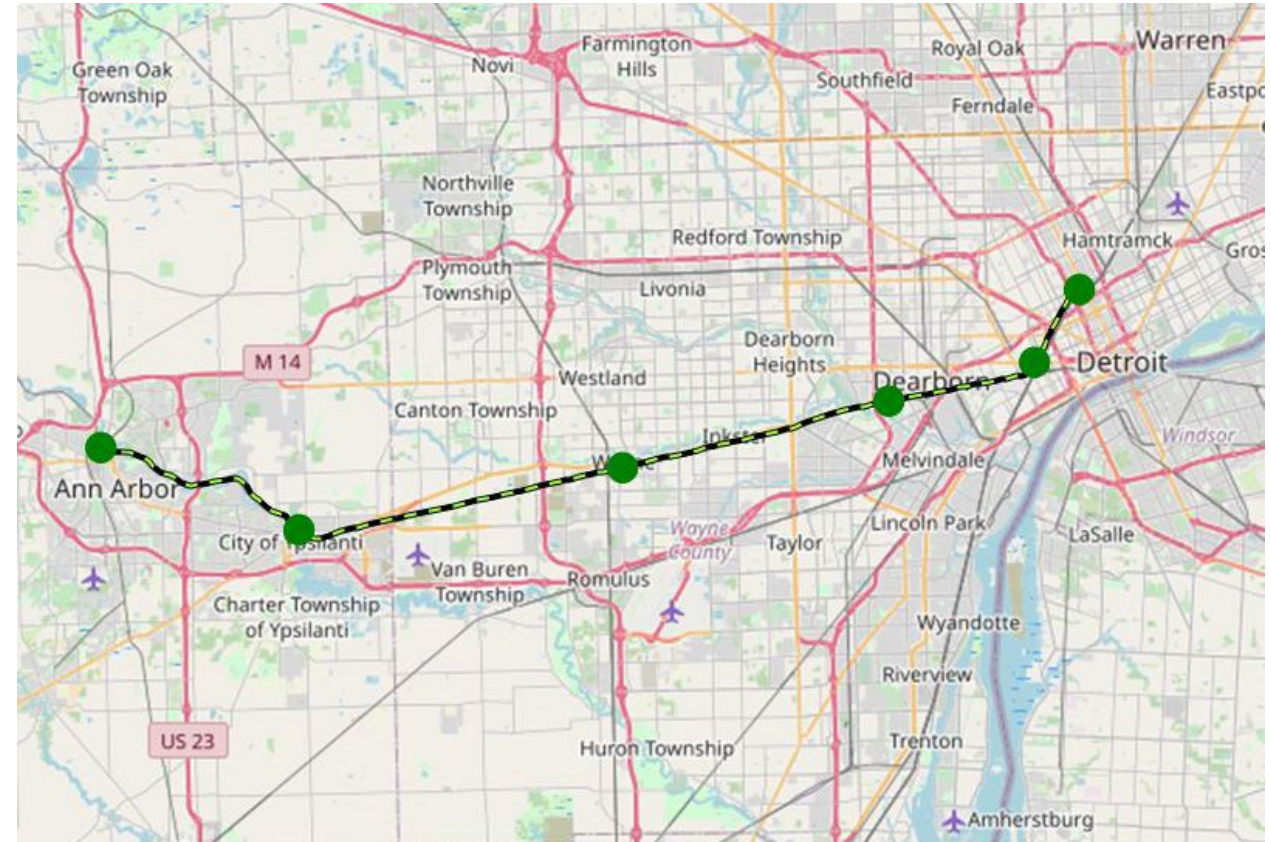

SEMCOG Commuter Rail Test

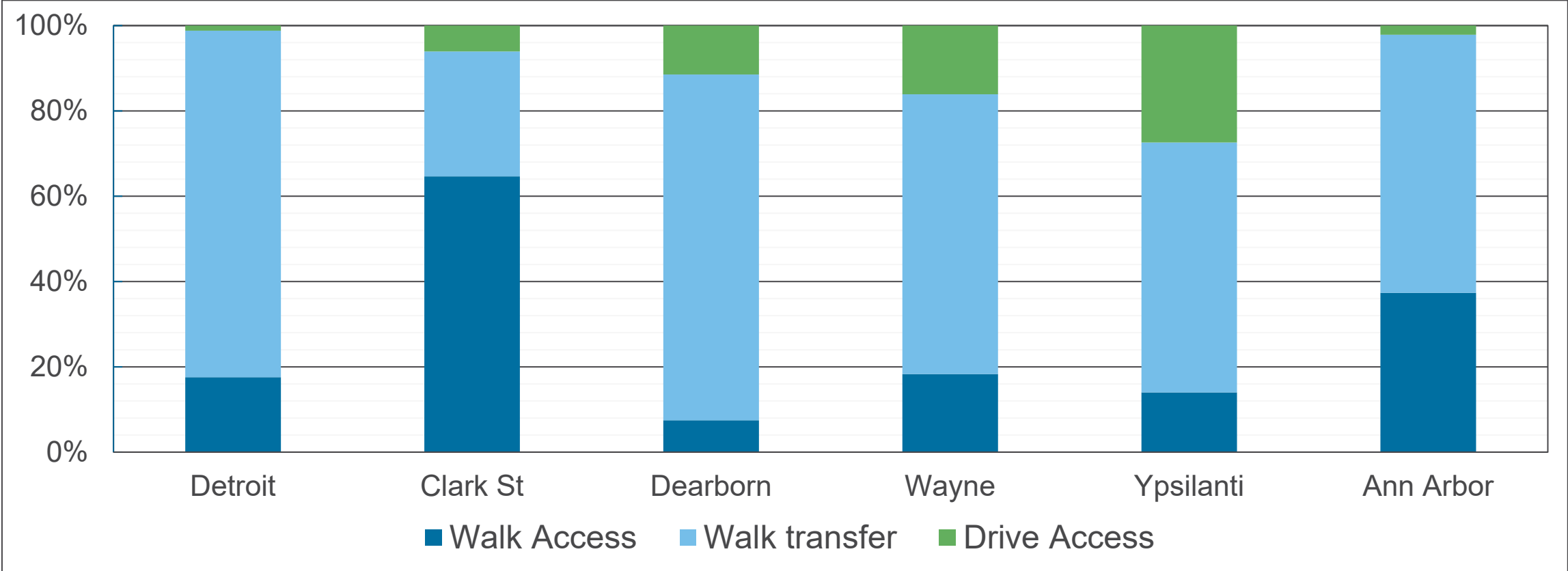

Summary

- **Many tests worked as expected**
 - Network tests
 - Income-based tests (TNC and Woodward Ave)
 - Auto operating cost tests
- **Two tests caused changes in the model**
 - Telecommute frequency test in MWCOG
 - Toll rate test in MWCOG

Planned Sensitivity Tests

MWCOG

- Bridge, Auto Operating Cost, and Transit Frequency Tests (re-run)
- Autonomous Vehicle Testing
- Equity Analysis

Metropolitan Council

- TBD

SEMCOG

- Major Employment Center Test
- Telecommuting and E-commerce Test



Contacts



ANDREW ROHNE (RSG)

Andrew.Rohne@rsginc.com

ALI ETEZADY (RSG)

Ali.Etezady@rsginc.com

JOEL FREEDMAN (RSG)

Joel.Freedman@rsginc.com

MARK MORAN (MWCOCG)

mmoran@mwcog.org

FENG XIE (MWCOCG)

Feng.Xie@mwcog.org

RAY NGO (MWCOCG)

rngo@mwcog.org

JONATHAN EHRLICH (MET COUNCIL)

Jonathan.Ehrlich@metc.state.mn.us

DENNIS FARMER (MET COUNCIL)

Dennis.Farmer@metc.state.mn.us

JILIAN CHEN (SEMCOG)

Chen@semcog.org

www.rsginc.com

