

***Washington Metropolitan Area
511 Feasibility Study***

***Technical Memorandum #3
Final Report***

Version 3

PBS&J Project # 071459.02

July 2005



Document Control Panel	
Document Name:	511 Feasibility Study Final Report
Document Location:	
Created By:	Pete Costello
Date Created:	April 9, 2004
Version No.:	2
Reviewed By:	Stacy Unholz, Brad Williamson, Todd Kell, Ben Morgan
Modified By:	Pete Costello
Date Modified:	May 23, 2005
Edited By:	Pete Costello
Date Edited:	July 12, 2005

Table of Contents

1.	Executive Summary	1
	1.1 Study Overview.....	1
	1.2 Study Activities to Date	1
	1.3 Feasibility Study Recommendations	3
2.	511 National Update	4
3.	Washington Metropolitan Area 511 Vision	7
4.	Conceptual System Design	8
	4.1 Information Content	8
	4.2 Telephone System.....	16
	4.3 Call Routing	17
	4.4 Business / N11 Environment.....	19
	4.5 Website.....	26
5.	Summary of Key Implementation Issues	27
	5.1 Assumptions and Description of the System	27
	5.2 Key Questions.....	27
	5.3 Summary of Costs	29
	5.4 511 System Implementation.....	29
	5.5 Data Fusion.....	32
	5.6 Telephone System Sizing	33
	5.7 Website.....	34
	5.8 Procurement and Operations.....	37
	5.9 Marketing	42
	5.10 Schedule	44
	5.11 Estimated 511 Costs	44
6.	RITIS, CapCom and 511 Implementation	49
	6.1 RITIS Background.....	49
	6.2 CapCom Background.....	51
	6.3 Regional Call and Cost Allocation Breakdown	52
7.	Feasibility Study Recommendations	55
	7.1 Develop an Outreach Plan.....	55
8.	Appendix A – Washington Metropolitan Area 511 Facility List ..	56
9.	Appendix B – Route Segments	60
10.	Appendix C: Summary of Available Content	62
11.	Appendix D – Implementation Plan Scenarios Version 2	63

1. Executive Summary

1.1 Study Overview

As part of its Statewide 511 Implementation, VDOT has tasked PBS&J to develop a Feasibility Study for 511 in the Washington, DC Metropolitan Area. A 511 Steering Committee – DC Metro Area (Committee) has direct oversight for the Study. Funding for the Study is through the FHWA’s \$100,000 planning grants for 511 with a local match of \$25,000. The District of Columbia (DC) originally obtained the planning grant (which was subsequently transferred to VDOT) and VDOT is providing the match funds.

The Committee decided that the Washington Metropolitan Area 511 Feasibility Study would utilize the 511 Guidelines (Guidelines) developed by the 511 Deployment Coalition as a baseline. VDOT’s 511 RFP looked for compliance with the Guidelines for the statewide 511 service.

The 511 Guidelines:

- Provide a “vision” for 511
- Have been reviewed by Advanced Traveler Information Systems (ATIS) experts
- Are nationally accepted

1.2 Study Activities to Date

PBS&J developed a Detailed Work Plan including a schedule for the Study, which was reviewed and approved by VDOT and the Committee.

PBS&J staff and its subcontractor, E-Squared Engineering, have discussed data sources and information availability for presentation on 511 with the stakeholders in the region. The following data sources / information types are being addressed:

- a. Highway – congestion, incidents, construction, closures, etc.
- b. Transit – service areas, schedules, fares, service delays, parking status, etc.
- c. Weather
- d. Tourism
- e. Bike, pedestrian
- f. Special events
- g. Emergency situations

The Study team has also reviewed the Data Source document dated October 7, 2004 developed by PB Farradyne, in supporting the Regional Integrated Transportation Information System (RITIS) project.

1.2.1 *Develop Conceptual System Design*

The Conceptual System Design of 511 services in the Washington metropolitan area:

- Provided a vision for 511 services
- Examined the information content to be provided
- Looked at the telephone system and call routing
- Noted the overall business environment in which the services operate in (including other N11 services like 311 and 211)
- Offered insight into 511 websites
- Uncovered issues for the Committee to discuss and resolve

1.2.2 *Develop Implementation Plan*

The Implementation Plan provided a roadmap for how the Conceptual System Design could be implemented and covered the following specific topics:

- Content – including Guidelines on Information Consistency, Accuracy and Quality
- Data Fusion
- Telephone System Issues – including menu structure, call routing and call volumes
- Website
- Procurement Approach, Business Model and Operations
- Marketing
- Schedule
- Cost Estimates for Initial Deployment and Ongoing Operations

The Committee, after reviewing the Implementation Plan, examined four possible 511 deployment scenarios (see Appendix D) for the Washington, DC metropolitan area:

- No Build – not have a Washington, DC metropolitan area 511 service
- Extension of 511 Virginia – add-on to the 511 Virginia service
- Independent System
- Part of Maryland Statewide System

1.2.3 *Finalize Feasibility Study*

The purpose of this document is to assess the findings of the preceding phases and provide recommendations on how to feasibly deploy 511 in the region. Options and recommendations have been included for the Committee to consider how to successfully deploy a 511 service to serve the travelers in the Washington, DC area while complementing existing or planned 511 services in bordering states or regions.

1.3 Feasibility Study Recommendations

511 is feasible in the Washington, DC metropolitan area. Data and information is available to help travelers make better decisions. There will be a regional information sharing database (RITIS) with a standardized output and an organization (CapCom) willing to take on operational responsibility. The region has two viable options for deploying 511, noted in the *Extension of 511 Virginia* and development of an *Independent System*. All four possible scenarios are discussed in Appendix D.

VDOT has made investments to serve Northern Virginia with 511 and additional funding from other stakeholders in the region would have to be agreed upon and could be based on population or another formula. In the *Extension of 511 Virginia* scenario, a Washington, DC metropolitan area 511 service would be built as an add-on to the 511 Virginia system. With the *Independent System* scenario, the Washington, DC area would build its own 511 system in addition to the 511 service offered by Virginia.

With RITIS data available from Maryland and the District in the early fall of 2005 and imminent funding decisions relating to the organization of CapCom, the Committee needs to make decisions relating to: the *Extension of 511 Virginia* or the *Independent System* options; who will be leading the Washington, DC metropolitan area 511 effort; and how to allocate funding.

2. 511 National Update

On March 8, 1999, the U.S. Department of Transportation (USDOT) petitioned the Federal Communications Commission (FCC) to designate a nationwide three-digit telephone number for traveler information. On July 21, 2000, the FCC designated 511 as the national traveler information number.

The FCC ruling leaves nearly all implementation issues and schedules to state and local agencies and telecommunications carriers. There are no federal requirements and no mandated way to pay for 511. Consistent with the national designation of 511, the FCC expects that the transportation industry will provide the traveling public with a quality service that has a degree of uniformity across the country.

In early 2001, mindful of both the opportunity and challenge that 511 presents, the American Association of State Highway and Transportation Officials (AASHTO), in conjunction with many other organizations including the American Public Transportation Association (APTA) and the Intelligent Transportation Society of America (ITS America), with the support of the USDOT, established a 511 Deployment Coalition. An executive-level Policy Committee and a supporting Working Group were established to conduct the work of the Coalition. Membership of the Coalition draws from all levels and types of government agencies, various segments of the telecommunications industry and the fields of consulting, system integration and information service provision.

The goal of the 511 Deployment Coalition is that 511 will be a customer driven multimodal traveler information service, available across the United States, accessed via telephones and other personal communications devices, realized through locally deployed interoperable systems, enabling a safer, more reliable and efficient transportation system.

As of publication, twenty-six services deployed in twenty-three states make 511 available to over 81 million Americans everyday – almost 30% of the total population – in twenty-one of the nation's top 60 major metropolitan areas. By the end of 2005, the 511 Deployment Coalition (www.deploy511.org) expects 511 service to be available to 45% of the population or 134 million Americans – see Figure 2.1. More 511 deployment-related information is available in the 2005 511 National Progress Report – available at <http://www.deploy511.org/docs/511%202005%20NPR%20Final.pdf>.

Through April 2005, over 33 million calls have been placed to 511 since the first service in the nation was launched in Cincinnati / Northern Kentucky on June 21, 2001. Annual call volumes have increased 65% for the last two years and in March 2005; over 500,000 calls were received by the 3 services in Florida alone.

Through local marketing efforts, the 511 brand awareness has reached over 40% in some areas and local customer satisfaction with the services is averaging 90%.

For more information on 511 benefits, see *The Value of Deploying 511* brochure – http://www.deploy511.org/docs/511_Value.pdf.

3. Washington Metropolitan Area 511 Vision

The vision developed by the Committee for the Washington metropolitan area 511 was based on the national 511 vision:

The Washington metropolitan area 511 is a customer-focused, multimodal traveler information service available across the region via phones, the Internet and other personal communication devices. The Washington metropolitan area 511 system will be interoperable with neighboring 511 systems resulting in a more satisfactory travel experience.

4. Conceptual System Design

4.1 Information Content

As per the 511 Guidelines (<http://www.deploy511.org/implementationguide.htm>) developed by the 511 Deployment Coalition, there are two main categories of information available on 511 services – basic and optional content. This Study examines the feasibility of both throughout the Washington, DC metropolitan area via the telephone and the Internet. The Committee has noted that the basic information available on 511 relates to reporting exceptions to “normal” conditions on the transportation system. The 511 Guidelines also allow optional content that is based on a region’s needs and information availability. The 511 Deployment Coalition encourages 511 implementers to consider providing optional content that will benefit callers and this Study explored the optional content that is available in the Washington, DC metropolitan area.

4.1.1 Coverage Area

The Committee has identified the geographic coverage area covered by the Washington Council of Governments’ Transportation Planning Board (TPB) for the Washington, DC Metropolitan Area 511 service– as seen in Figure 4.1:

- District of Columbia
- Virginia
 - Arlington County
 - Fairfax County
 - Loudoun County
 - Prince William County
 - City of Alexandria
 - City of Fairfax
 - City of Falls Church
 - City of Manassas
 - City of Manassas Park
- Maryland
 - Montgomery County
 - Prince George’s County
 - Frederick County
 - Charles County



Figure 4.1 – National Capital Region 511 Coverage Area

4.1.2 Basic Content

Roadway Content

The Guidelines note that as the primary means of travel in the United States, roadways (highways and arterials) and information about major roadways should be a principal part of a 511 system. The core of many existing traveler information services is highway conditions reporting and there are five key principles associated with roadway content:

1. *Regional Overviews or Summaries* – allow users to get important information quickly, (i.e., incidents or service disruptions that may impact one’s trip) without having to go through the

entire menu system. Upon hearing the overview, the caller would be able to select the specific route or segment to obtain detailed information.

2. *Content is Route / Corridor-based* – provide information that is retrievable by route number and / or name. When a route / corridor is operated by multiple agencies, these agencies should work together to provide an integrated description of conditions.
3. *Limited Access Roadways and the National Highway System Should Be Covered by the Basic 511 Highway / Roadway-related Content* – the 160,000 mile National Highway System should be the focus of basic 511 content. Limited access roadways should also be part of the basic content.
4. *More Detail Needed in Urban Areas* – Given the increased traffic volumes and congestion levels in urban areas, even minor events could have large impacts on travel.
5. *Content is Automated* – information should be stored and automatically provided to callers. There need not be any direct contact between callers and human operators to provide basic highway content.

Proposed Roadway Content

Regional Reports – available for the District, Northern Virginia and Maryland at a minimum. More detailed, roadway specific information will also be available should the traveler wish to “drill down.”

Roadway Coverage – the Freeways, Expressways, Parkways, Major Arterials, Major Interstate Connectors and Bridge facilities for which 511 should provide exception reporting are noted in Appendix A. Most of these facilities do not have automated congestion data available, but they are the major facilities that should be covered by a regional 511 system.

Segments – one factor that makes providing information via 511 an art, not a science, is the determination of logical segments of roadway to convey information to the traveler. With too many segments, the traveler does not receive the necessary information relative to decision points on their trip and too few segments can overwhelm the traveler with information. For example, the proposed segmentation of the Capital Beltway is: the Wilson Bridge to the Mixing Bowl; the Mixing Bowl to I-66; I-66 to the American Legion Bridge; the American Legion Bridge to I-95; and I-95 to US 50; and US 50 to the Wilson Bridge. Information for these segments would be covered in two regional reports– one for Maryland and the other for Virginia. Segments are noted in Appendix B.

For each segment, specific types of content should be provided:

- *Construction / Maintenance Projects* – Current information on active projects along the route segment that may affect traffic flow and / or restrict lanes.
- *Road Closures and Delays* – Unplanned events, incidents or congestion that shut down or significantly restricts traffic for an extended period.

- *Major Special Events* – Transportation-related information associated with significant special events (festivals, sporting events, etc.).
- *Weather and Road Surface Conditions* – Weather or road surface conditions that could impact travel along the route segment.

For each of these highway content types, it is necessary to provide details that enable callers to assess travel conditions and make travel decisions associated with a route segment. Figure 4.2 illustrates the detailed information needed for each content type.

- *Location* – The location or portion of route segment where a reported item is occurring, related to mileposts, interchange(s) and / or common landmark(s).
- *Direction of Travel* – The direction of travel where a reported item is occurring.
- *General Description and Impact* – A brief account and impact of the reported item.
- *Days / Hours and / or Duration* – The period in which the reported item is “active” and possibly affecting travel.
- *Travel Time or Delay* – The duration of traveling from point A to point B, a segment or a trip expressed in time (or delay a traveler will experience). Due to a lack of data, many 511 systems are not providing this information.
- *Detours / Restrictions / Routing Advice* – As appropriate, summaries of required detours, suggested alternate routes or modes and restrictions associated with a reported item.
- *Forecasted Weather and Road Surface Conditions* – Near-term forecasted weather and pavement conditions along the route segment that impact travel.
- *Current Observed Weather and Road Surface Conditions* – Conditions known to be in existence that impact travel along the route segment.

Content Type	Content Detail								
	Location	Direction of travel	General description and Impact	Days / Hours and / or duration	Travel time or delay ¹	Detours / Restrictions / Routing advice	Forecasted weather and road surface conditions	Current observed weather and road surface conditions	
Construction / Maintenance	✓	✓	✓	✓	✓	✓			
Road Closures / Major Delays	✓	✓	✓	✓	✓	✓		✓	
Major Special Events	✓			✓	✓	✓			
Weather and Road Conditions	✓		✓				✓	✓	
Incidents / Accidents (Minor)*	✓	✓	✓						
Congestion Information*	✓	✓	✓		✓				

* Major congestion information and incident / accidents are considered part of the “Road Closures / Major Delays” content type
 1 – Desirable if the deployer has the capabilities to include this information as part of the service

Figure 4.2 – Basic Content Detail Needed for Each Highway Content Type

Based on PBS&J’s interviews with stakeholders regarding data available for 511, there is sufficient data to provide actionable information to travelers in the region. The data sources and their availability on 511 are further detailed in the Implementation Plan.

Public Transportation Content

The Guidelines note that public transportation operators already have established methods of communicating to the public about their services, including websites and customer service centers accessible by telephone. If properly utilized and coordinated with these existing communications methods, 511 can assist public transportation operators in better serving their customers and possibly even attract new customers.

Information access via telephone has proven to be extremely important in transit customer service. 511 should assist in providing travelers with general agency and service information and communicating service disruptions and changes. Travelers should be transferred to the agency or directed to where they can obtain more detailed information and trip planning.

There are four basic principles related to public transportation agency information provision on 511:

1. *Information on All Transit Agencies in the Area Should Be Available* – public transportation operators should be accessible via 511 by identifying specific agencies.
2. *511 Works in Conjunction with Transit Customer Service Centers* – 511 is not intended to replace these operations, but to provide compatible and supplemental information, usually in the form of recorded scripts. Travelers would have direct access to these customer service centers via a call transfer.
3. *511 Should Minimize Additional Customer Service Center Overload Via Automated Messages* – 511 access could increase the number of callers seeking public transportation information. The Washington metropolitan area 511 system will provide automated messages that will answer many callers' questions prior to seeking assistance from customer service center operators.
4. *Each Agency Responsible for Their Information* – To ensure information quality and agency autonomy, any information provided via 511 for a particular public transportation operator must be provided or quality-checked by that agency.

Proposed Public Transportation Content

- Public Transportation Agencies
 - Alexandria DASH
 - Arlington Rapid Transit
 - Fairfax Connector
 - Fairfax CUE
 - Falls Church GEORGE
 - Loudoun County Transit
 - MARC
 - Metropolitan Washington Airports Authority
 - Montgomery County Transit – Ride On
 - PRTC (serving Prince William Co.)
 - Transportation Association of Greater Springfield (TAGS)
 - TheBus (Prince George's County)
 - VRE
 - WMATA
- Service disruptions / exceptions
- Brief agency description with call transfer option

Weather Content

From the Guidelines, the overriding basic principle for providing weather information is simple: if weather will impact a person's trip, then they should be alerted to that actuality or possibility. Rain, ice, snow and even glare can have huge impacts on travelers in the Washington

metropolitan area. With that being said, weather should not be a “top level” menu option on the 511 system, rather it should be presented, when applicable, as roadway content and public transportation “exception” messages.

National Weather Service warnings and advisories should be available to travelers as floodgate messages (played before the main menu and category menu script) due to their likelihood to impact the entire region. Those watches, warnings and advisories that do not affect the entire metropolitan area should be available as regional reports. Should a public transportation agency wish to report the weather impacts on their services, they should utilize a recorded exception report for their agency.

Winter road conditions may be addressed in roadway content as well – e.g., snow emergency routes are in effect in the District.

4.1.3 Optional Content

The 511 Guidelines allow optional content that are based on a region’s needs and information availability. The Coalition encourages 511 implementers to consider providing optional content that will benefit travelers. This Study identified the following optional content, provided by the Committee, which is available in the Washington, DC metropolitan area that should be included in the basic service:

- Roadway Content
 - Security Measures and Closures
 - Special Events
- Public Transportation
 - Airports
 - Carpool / Vanpool
 - Major Public Transportation Delays
 - Security Measures and Closures
 - Special Events
- Emergency Alerts
 - AMBER Alerts
 - Heightened Security Alerts
 - Security Measures and Closures
- Tourist Information – handled through floodgates by the appropriate convention and visitors agency. For example, the Washington, DC Convention and Tourism Corporation would provide an audio version of their “travel update” webpage. Tourist agencies should be responsible for the details and costs associated with maintaining their information. More detailed information would be available to website users through hyperlinks.

4.1.4 Content Quality and Consistency

The Guidelines note that the accuracy, timeliness and reliability of information on 511 is an important issue for 511 deployers and users as well. In an increasingly advanced information society, travelers are generally accustomed to high quality information and 511 content must be no different. The Intelligent Transportation Society of America (ITS America), in its national consumer research on 511, determined that “those surveyed said that if they used 511 and found the information to be inaccurate in their first few uses, they would be unlikely to give the service another chance.” This is a KEY reason why public relations and marketing need to be involved from the outset – to help manage the image of this regional program.

There are five quality parameters for 511 implementers:

1. *Accuracy* – reports should contain information that matches actual conditions. If the system reports events that are not occurring or does not report an event that is occurring, travelers will come to distrust the information provided. If inaccuracies persist, travelers will discontinue their use of 511.
2. *Timeliness* – closely related to accuracy, information provided by 511 should be timely to the greatest extent possible in accordance with the dynamics of changing conditions. Information should be updated as soon as there is a known deviation from the current route segment or service report.
3. *Reliability* – travelers use highways 24 hours a day, 7 days a week. The most challenging travel conditions can be experienced during nighttime and on weekends, so methods must be developed to provide travelers with a reliable stream of information 24 / 7.
4. *Consistency of Presentation* – it is recommended that reports use the same, or similar, terminology to describe conditions. This includes development of “style guide” for terminology and guidelines that all agencies agree to adhere to.
5. *Relevancy* – the information that is provided needs to be relevant to the traveler given their location, modal choice and / or actions that they may need to take as a consequence of weather, road conditions or service disruptions.

4.1.5 Other Content Issues

Amber Alerts / Security – handled through floodgates, we recommend that a clear Concept of Operations be developed on when these are activated, message structure, what authorizations are required to activate, etc.

Timestamping – Maryland’s CHART system (which DDOT also utilizes) and VDOT’s VOIS data are available with time stamps for the information. Timestamps should be utilized to give travelers a reference as to the latency of the information.

Other Optional Services – the Committee needs to determine if the 511 system will provide the following information/ functionalities:

- Travel Time or Other Enhanced Traffic Information (e.g. Alternate Routes)
- Parking
- Personalized / Customizable Services
- Points of Interest
- Highway Advisory Radio (HAR) content
- VMS / DMS content

4.2 Telephone System

As per the Guidelines, key telecommunication elements of a 511 service allow the system to accept calls, interact with the users, process queries and commands and provide useful information back to the callers.

Accepting calls – The service should be capable of accepting calls from both wireless and landline phones, wireline from the desired cities and counties with “over coverage” in Maryland counties for wireless carriers based on switch geometry.

User Interface – The telephony system user interface shall be fully voice-activated and based upon state-of-the-art speech recognition technology, with touchtone backup capability and voice shortcuts to allow easy navigation for regular callers while minimizing call length.

The Washington, DC metropolitan area 511 Traveler Information System should be a privately hosted network-based system, meaning that the system should not be “on premise” at an agency in the region. Availability for this system should be 24 / 7 / 365. The system should be scalable, easily able to manage call transfers and designed to incorporate floodgate messages at all levels of the menu structure.

A Conceptual Menu for 511 in the Washington, DC metropolitan area is shown in Figure 4.3 for illustrative purposes to allow stakeholders to visualize how the menu tree could be structured.

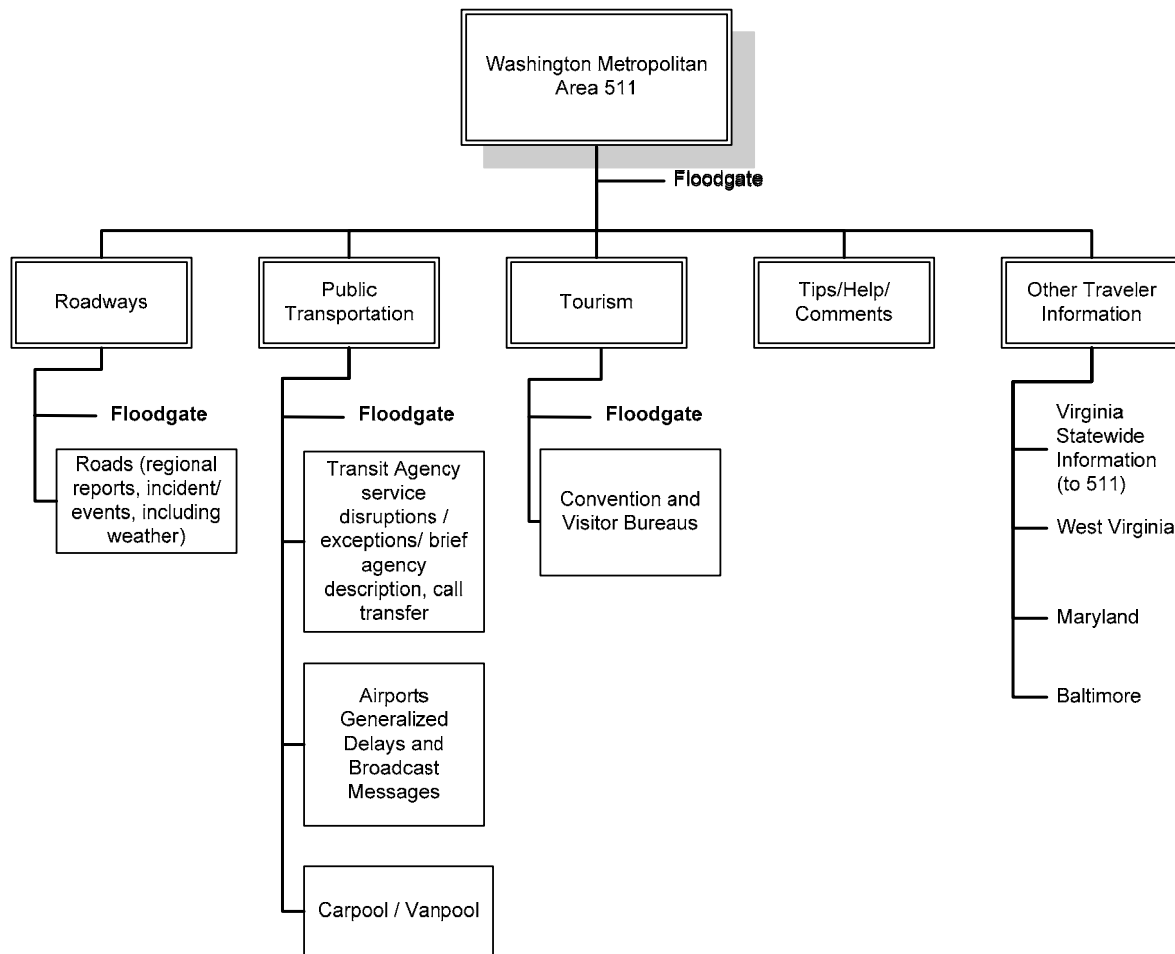

Figure 4.3 – 511 Conceptual Menu

4.3 Call Routing

From the Guidelines, a successful 511 service has seamless and reliable call routing and these should go virtually unnoticed by the user – the call goes through and the call gets answered. Call routing and carrier coordination is not a trivial matter, for both wireline and wireless carriers.

When 511 is dialed on a wireline phone, the call is received by the telephone company central office and translated into a 7 or 10-digit number, where the call is answered by an automated 511 system.

For wireless calls when 511 is dialed at the handset, the call is received by a cellular tower and carried to a switch where the 511 code is translated into a 7 or 10-digit number, where the call is

answered by an automated 511 system. Each of these routings has various cost implications associated with them.

With an operational service in Virginia as of February 1, 2005, there are many telecommunications issues related to initiating 511 service in the region. Unfortunately, the calling areas that telecommunications carriers established – Local Access and Transport Areas (LATAs), central offices and switches – do not neatly follow political boundaries and jurisdictions.

4.3.1 Wireless

There are five major wireless carriers (Verizon, Cingular / AT&T Wireless, Sprint PCS, Nextel and T-Mobile) and many smaller wireless carriers with which to coordinate routing of 511 calls. To insure proper coverage and that the traveler contacts the system that provides desired information in the region, routing of calls at the cell tower level may be necessary. Cell tower programming has cost implications for 511 in the Washington metropolitan area. Cell tower programming costs vary by carrier and can range from less than a hundred dollars per tower to thousands of dollars per tower. In order to keep 511 calls pointed to the proper number for the Washington Area (versus say a future Baltimore or Maryland statewide 511 deployment) each tower on or near the coverage area border in Maryland would have to be programmed. This could be an expensive undertaking.

4.3.2 Wireline

Verizon is the dominant landline provider (one of the incumbent local exchange carriers or ILECs), but there are countless other competitive local exchange carriers (CLECs), such as Starpower, Sprint, Cox and Comcast. The DC Public Service Commission regulates 11 ILECs and 189 CLECs – 41 of whom provide service. The Virginia State Corporation Commission regulates 14 ILECs and 191 CLECs throughout the state. The Maryland Public Service Commission categorizes telecommunications companies somewhat differently and regulates 132 ILECs and 92 resellers of local service. This may sound daunting, but most local wireline service is provided by a few large telecommunications carriers. Most landline providers charge for 511 call translations. The preferred fee structure for a deployer is a one-time charge with no recurring (monthly) costs. However, the costs can vary significantly by carrier.

4.3.3 Access for the Hearing Impaired

An emerging issue for 511 is the accessibility of systems and information by the hearing impaired. For example, a caller to the 711 relay service for the hearing impaired wanted information from the Tampa 511 service and the 711 operator in a facility in Miami connected the hearing impaired caller to information from the local Miami 511 service. To ensure access to the disabled community, the “back door” number to the service should be publicized to enable hearing impaired callers to access traveler information that they desire. Additionally, the relay

center should also know what each of the 511 back door phone numbers are for the states and cities they serve.

4.3.4 Payphone and Private Branch Exchange (PBX) Access

511 may not be accessible due to default manufacturer settings in PBX systems that companies and institutions utilize. Most would need to dial “9” before dialing 511 or may need to use the full 7 or 10-digit phone number initially. A page on the co-branded website noting the PBX access issue with instructions on making the programming changes or directing companies to contact their PBX manufacturers should be sufficient to address this issue.

The Committee may wish that payphones provide access to 511 to serve all socio-economic strata of the population. This is an especially important consideration for transit users. The number of payphone providers in a 511 service area usually outnumbers CLECs as some payphone providers may only own one payphone with Verizon being the dominant payphone provider in the region. Offering payphone access also has cost implications for the service and has not been a focus of any of the 511 deployers to date.

4.4 Business / N11 Environment

From the Guidelines, basic services should be no more than the cost of a local call and the deploying agencies should expect to fully fund the 511 service and its level of information for the foreseeable future. Advertising and sponsorship are acceptable, as long as they do not interfere with the user’s primary intent for calling the service. Fee-generating premium or enhanced services are also acceptable, though a market for these services has not been established yet. As discussed in Section 4.4.2, currently, no 511 service has established a positive revenue stream through sponsorships or premium services, though VDOT is testing a variation of this business model with their statewide deployment.

4.4.1 Operations and Maintenance Costs

511 essentially is the “speed dial” for transferring calls to a traveler information system as seen in Figure 4.4. The routing of 511 calls usually involves telephone switch or central office programming to direct calls appropriately and, with some telecommunications carriers, recurring monthly or annual charges. Interactive voice response (IVR) telephone systems allow access via voice recognition or

Figure 4.4

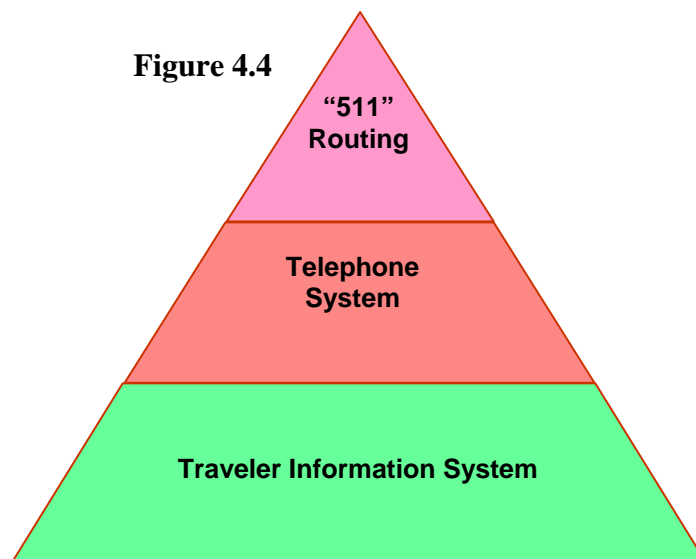

keypad input to information developed from transportation network data by a traveler information system. There are costs associated with each of these steps up the 511 hierarchy.

Operations and maintenance expenditures associated with 511 services may increase over time if, as is expected, usage builds due to the network effect of having more and more 511 systems and their marketing efforts resonating with travelers.

511 deployers do not all account for their costs in a similar manner, so an “apples to apples” comparison between services and similar states and regions can be difficult. The 511 Deployment Coalition has done some cost research which is contained in *The Value of Deploying 511* document (http://www.deploy511.org/docs/511_Value.pdf). The services surveyed for that document were rural statewide services and the cost information has little applicability when considering costs for 511 services in the Washington, DC metropolitan area.

To get a better picture of operations and maintenance costs that the Washington 511 service can expect, one must look at the existing 511 systems serving metropolitan areas:

- Sacramento
- San Francisco Bay Area
- Orlando
- Southeast Florida (Miami, Fort Lauderdale and West Palm Beach)
- Tampa
- Cincinnati

The above services were contacted about costs incurred to operate and maintain their systems and the source of these funds. Responses were received to our inquiries from most of these deployers.

The San Francisco Bay Area spends approximately \$6 million per year offering 511 from Surface Transportation Program (STP) and local match funds. Orlando is in the process of upgrading its 511 service through the iFlorida Model Deployment with an additional \$500,000 for system planning and design and application development and testing and \$265,000 per year for operations personnel and telephone service minutes. The Southeast Florida 511 service costs FDOT, the Florida Turnpike and the Miami-Dade Expressway Authority approximately \$1 million per year with funds from those agencies. FDOT is upgrading the service with a regional transit information database partially funded by transit agencies serving the region. Tampa is spending \$8.2 million for ATIS and the Intelligent Transportation Infrastructure Program over five years with \$7 million from FHWA and \$1.2 million of state funds. Cincinnati recently switched the provider of its 511 service and incurred system development costs of \$400,000 and expected operations and maintenance costs of \$60,000 per year from Ohio and Kentucky state funds. When the Cincinnati service was launched in 2001, it utilized a combination of National Highway System (NHS) and Congestion Mitigation and Air Quality (CMAQ) funding.

The above cost information highlights the disparity of costs reported to the 511 Deployment Coalition, but does give the Washington area stakeholders a number of data points to consider. Gathering the above information, PBS&J also realized that the above deployers did not account for all their costs, especially agency labor associated with these 511 systems, but nevertheless this data is important for consideration in the implementation of 511 for the Washington metropolitan area.

It would be safe to say that an independent 511 system for the Washington area would likely cost about \$1 million for operations and maintenance, whereas a shared system (with Virginia) has the potential to be measurably less expensive.

4.4.2 Identification of a Business Model

The 511 Deployment Coalition's Deployment Assistance Report #1: Business Models and Cost Considerations (http://www.its.dot.gov/511/511_Costs.htm) notes that "public sector funding is likely required for near-term implementation and continued operations" of 511 services. To date, no sustainable, innovative business models for 511, and ATIS in general, have been utilized. VDOT's travel services offering in the statewide implementation of 511 presents perhaps the best opportunity to explore an alternative business model for 511 services.

VDOT is seeking sponsors to advertise in the initial greeting and with listings under travel services on the telephone service and on banner ads on the website. A six-month trial to test the business environment and response from advertisers began when the statewide service was launched in February 2005. The generation of advertising revenue from 511 services is hoped to defray a portion of the cost for the entire service. Primarily, the revenue must fully support the Travel Services feature of the 511 system or that feature will be removed as it is not viewed as a core service or responsibility of VDOT's. Even if VDOT's trial is successful, VDOT will continue to provide most of the resources for 511 services in Virginia.

Public relations and marketing should be involved with this process as a key partner. They should help advertisers manage the messages and sell the space available ensuring that 511 messages are consistent throughout. Of course, with cross branding and advertising partnerships, each organization risks potential damage to their image if something negative becomes associated with either 511 or the advertiser.

In the mid- to late 1990s, a business model that was in favor with the travel information industry would allow the system to generate major revenues to offset the costs to public sector agencies in offering traveler information. The Washington area has experience with this business model through Partners in Motion, as discussed in Section 4.4.4. Today, that model is in disfavor in the ATIS industry, because it was not supportable. The exception is the recent RFP from the San Diego Association of Governments (SANDAG) for an ATIS with 511 telephone and website services. This RFP was met with skepticism by the industry, which does not believe the business model to be financially viable in the long-term.

Implementation of 511 services in the Washington metropolitan area should anticipate public sector funding to provide these services to travelers.

4.4.3 Funding Strategy and Sources

PBS&J understands that it is the intent of the region to use ITS earmark funding for the 511 service that require a 50% (dollar for dollar) match including a 40% match from non-federal sources (20% of the total project costs) and 60% (30% of the total project costs) from other sources including other federal funds / projects. The entire ITS earmark program is being reviewed by U.S. DOT and may not continue, or at least continue in its current form, under reauthorization.

511 services in other metropolitan areas, have successfully utilized FHWA, STP, NHS, CMAQ and agency funding – including from transit and toll agency partners. An example of the use of CMAQ funds in the region is the \$1 million per year that DDOT utilizes for the Roadway Operations Patrol – an emergency service patrol that assists motorists.

All of these funding sources merit examination for their applicability in the provision of 511 traveler information services for the Washington metropolitan area. The stakeholders in the region have an opportunity to fund the 511 services in a unique multi-agency manner across state lines and modes. Currently, the only other metro area / multi-state 511 system in the country is in Cincinnati, which has a long history of working cooperatively to share funding and operational resources.

The 511 service in Southeast Florida is supported by the local Florida DOT District, the Miami-Dade Metropolitan Planning Organization, the Miami-Dade Expressway, the Florida Turnpike and three transit agencies. These agencies made a decision years ago to support ATIS through line items in their agency budgets to better serve their customers.

4.4.4 N11 “Lessons Learned”

The Washington, DC metropolitan area has experience with other N11 services besides 911 and 411 that can help in its development of plans for a 511 implementation. The Washington Metropolitan Police Department (MPD) offers 311 for access to the police in non-emergency situations. The City of Baltimore offers 311 for access to the police in non-emergency situations and other city services. The previous Partners in Motion traveler information project offered access to some wireless telephone callers to its information via #211. On October 5, 2004, Mayor Anthony Williams announced that 211 was available for District residents to receive social services through the District’s Department of Human Services. While each of these abbreviated dialing codes are not directly relevant to developing and supporting a 511 service, they do hold some good local experience and background for the region.

311 Experience

Washington, DC

Washington, DC's 311 service became operational in September 1999. Prior to implementing 311, the city had a 7-digit police non-emergency telephone number which the public was using for non-emergency related issues. Over the years, 311 has become highly utilized with over one million calls placed to 311.

There are still many instances in which individuals are calling 911 for non-emergency situations. Citizens are reminded to call 311 to report situations that are not serious, not life-threatening or not currently in progress. The District launched a public education campaign that encourages residents to "make the right call -- 311 for police non-emergencies." 311 was advertised with posters on Metro buses and trains, radio commercials and the city government website. Informational and promotional materials were also made available to businesses and community groups.

Fees to fund 911 access are collected by Verizon as a part of the regular billing for residential phone service. Verizon also controls the expenditure of these funds for 911 service, equipment and upgrades. Legislation that would transfer control of these fees to the District government is pending before the City Council. This legislation is a critical step in allowing the MPD to make further improvements to their 911 and 311 systems. It would be highly unlikely that this type of funding mechanism would be possible to support 511 services in the Washington, DC metropolitan area.

MPD and the Office of the Chief Technology Officer plan a merger of various call taking operations in the city into a 311 combined city services and police non-emergency system at a consolidated call center. The center has goals to improve service delivery, realize cost reductions and economies of scale, better enable employee recruitment and retention and coordination among public safety agencies with enhanced facility security and improved 911 and 311 services.

On August 3, 2004, the City awarded a contract to build the final phase of the Unified Communications Center. The \$43 million contract is one of the largest construction contracts ever awarded by the District and the projected completion date for the facility will be in the fall of 2005.

Baltimore

Baltimore became the first city to have an operational, non-emergency number with support from a Community-Oriented Policing Services (COPS) Non-Emergency Telecommunications Pilot Project grant on October 1, 1996. The following year, after a request by the U.S. Department of Justice's Office of Community-Oriented Policing Services and an endorsement by President

Clinton, the Federal Communications Commission designated 311 as the national 3-digit number to be used for all future call centers. The Commission stated that use of this code could improve the effectiveness of 911 emergency services by alleviating congestion on 911 circuits.

311 has been a resounding success for Baltimore. 911 call volume has been reduced and 311 has allowed the emergency phone system to operate more efficiently and effectively. The first two years of Baltimore's 311 service were paid from the COPS federal grant and with City funds since.

The Baltimore Police Department recorded the following improvements since 1996:

- Average answer time for 911 calls was reduced by 50 percent
- Percentage of 911 calls where the caller hangs up were reduced by 50 percent
- Average time between incoming 911 calls increased from 70 to 143 seconds
- Percentage of 911 calls receiving a recorded message was reduced from 18 percent to 4 percent
- Average "total position busy" time was reduced by 169 hours each month and the percentage of time operators were busy on calls was reduced from 59 percent to 41 percent
- From September 1996 to September 1999, the number of police calls dispatched to field units was reduced by 12 percent

Prior to implementing 311, the Baltimore Police Department did not have a 7-digit non-emergency telephone number for citizens to dial. If you needed the police in Baltimore, you dialed 911.

The University of Cincinnati surveyed Baltimore residents and concluded that the citizens had an overall favorable view of 311 services. The citizens generally agreed that 311 improves city services, improves police community relations, should be used for non-emergency calls only and leads to fewer non-emergency calls to 911. Over 90 percent of respondents felt that 311 call-takers were both polite and helpful and were overall satisfied with the service provided.

On March 25, 2001, Baltimore introduced the 311 One Call Center, joining existing police and fire emergency communications facility. The One Call Center was staffed with existing City call-takers, relocated from other City operations, as well as new hires. These 75 agents handle over 5,000 calls per day, 24 / 7 / 365. With the One Call Center, Baltimore also introduced a new 311 system combined with other City services beyond public safety. This new 311 system utilizes customer relationship management software and provides for both centralized and distributed call intake and work order management throughout the City.

Mayor Martin O'Malley reported in 2001 that Baltimore had received 560,574 calls to its 311 line. When Mayor O'Malley expanded 311 to include easy public access to all non-emergency

government services, it was estimated that Baltimore saved \$13.2 million by eliminating redundancy, overtime and extraneous expenditures.

Partners in Motion

From July 1997 to December 2002, the Washington region was served by the Partners in Motion advanced traveler information system. VDOT oversaw the project for stakeholders in the region and travelers could access information through a website and IVR telephone service. The access number was #211 for a limited number of wireless callers and (202) 863-1313, and later (301) 628-4343, for the general public. Throughout the course of the project, the Partners in Motion telephone service received over a quarter of a million calls with a peak call volume of 13,611 calls in May 2000 – healthy demand for a unique, regional ATIS service.

There were some data issues associated with the Partners in Motion project as the private sector was to collect transportation network data, which was not delivered to consumers.

The calls received by the telephone service are shown in Figure 4.5 below:

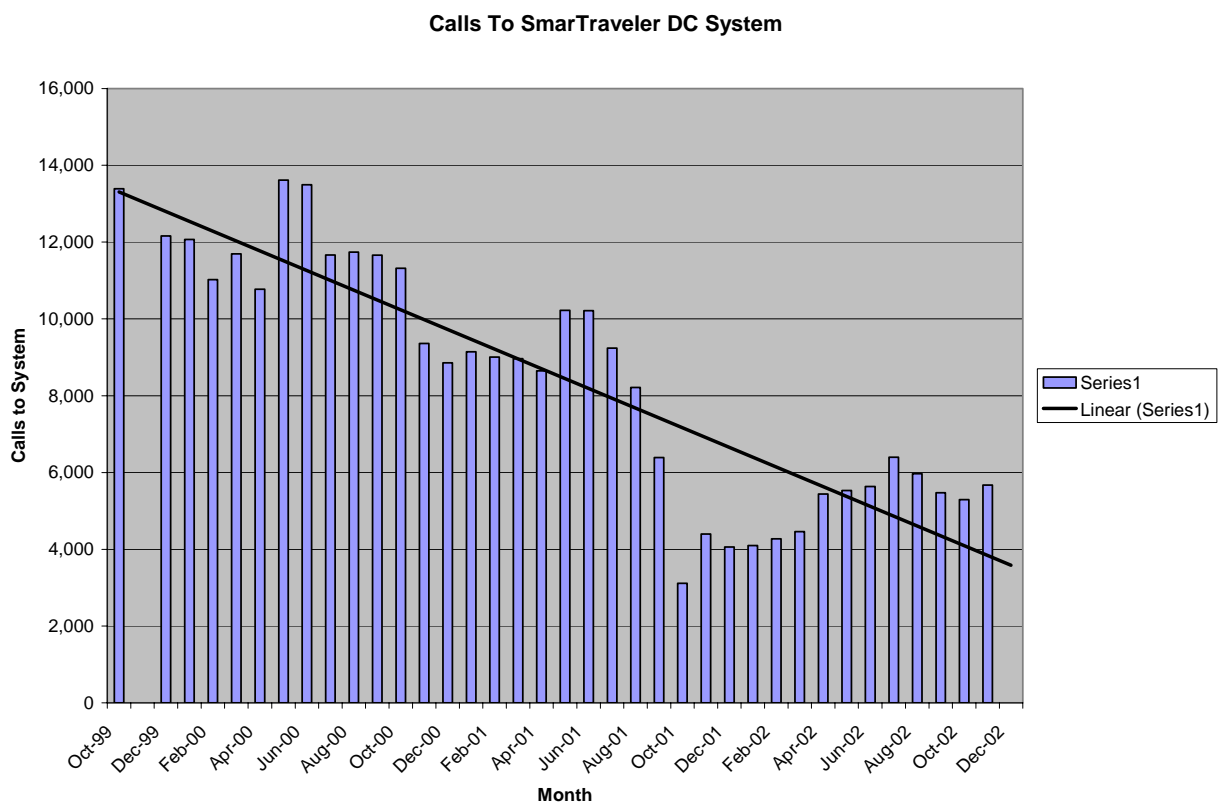

Figure 4.5 – Partners in Motion Call Volumes

Over time, calls to the service decreased and this serves as an important lesson to whoever implements 511 and its need for sustained marketing to consumers. Granted, Partners in Motion did not use the “easy to remember” N11 access code for all callers, but website usage showed a similar trend over the course of the project as well. When 511 services are implemented, deployers can see a 300 to 600 percent increase in the number of calls to their legacy systems.

Partners in Motion had a business model that was in favor when it was implemented where ATIS would generate major revenues to offset the costs to public sector agencies in offering traveler information. There are no 511 services in place today relying on this failed business model.

4.4.5 Applicability to 511

When 511 services are offered in the Washington metropolitan area, educating consumers on the types of information available through 511 is paramount. The other N11 services and the kinds of information / assistance available should be documented on the website where system usability is demonstrated. This will help to alleviate potential confusion as to what is available from 211 and 311 on the part of consumers and help “brand” the 511 information offering.

4.5 Website

Version 2.0 of the Guidelines states that there is a good opportunity for co-branding with websites, but does not have guidelines addressing websites per se. Version 3.0 of the Guidelines to be released in July 2005 will cover this topic in more detail, so we look to apply lessons learned from other urban areas.

The integrated website should be easy to navigate and accessible using a standard Internet browser. More detailed information may be available on the website due to its graphical, rather than aural, interface. The information on the Washington metropolitan area website should be consistent with information available on the 511 telephone service. The interface should be designed to minimize load times and the number of “mouse clicks” necessary to view the desired information.

All links and icons should provide context help in the form of “mouse-overs” that describe the function and / or purpose of the corresponding link or icon. The overall visual design of the interface should be easy to read, using brief, non-technical language that is readily understandable by the average user, and easy to use for a user with basic computer skills.

5. Summary of Key Implementation Issues

This section lays out the assumptions underlying this study and describes what the 511 system will look like; summarizes the key questions still facing the committee; and provides high-level cost estimates for the deployment.

5.1 Assumptions and Description of the System

This section lists the assumptions that were made and then provides a description of the resulting system. It is important to realize that the assumptions are just that, and may or may not be the approach ultimately taken by the Committee.

The key assumptions are as follows:

- The system will use only existing data sources, and will not develop new data
- One agency will take the lead in developing, deploying, and operating 511, but other agencies will contribute staff time, in-kind marketing, and, potentially, funding

Using these assumptions, the 511 service for the Washington, DC system will have the following characteristics:

- Callers dialing 511 on landline and wireless phones in the coverage area described in Section 4.1 will reach the Washington, DC 511 service
- Roadway content will include incidents, construction, weather and special events on the roadways listed in Appendix A
- Congestion information will be available for interstates in Maryland, and could be used to provide travel times
- Callers will be able to transfer to transit agencies, airports, and Virginia's 511 system
- Optional content, as described in Table 4, will be available
- There will be a web presence, but the exact nature of it is yet to be defined

5.2 Key Questions

In order to implement the system described above, the Committee will have to answer the following key questions. For each question, we provide some context as to why it is relevant and recommend an answer, when possible.

1. Will it be an independent system or will it be part of the 511 Virginia service? The advantages of an independent system are that it can be an independent system, designed specifically to reflect the Washington, DC region's needs. The disadvantages are that it will cost more and will take longer. An additional consideration relates to call routing.

As of February 1, 2005, calls in the Virginia portion of the Washington, DC area will be routed to the 511 Virginia system. If the Washington, DC system is an independent system, callers in Virginia will have to be routed away from a system with which they will have become familiar and into a new system.

Recommendation: The Committee will have to balance the desire to have an independent system with the cost, schedule implications, and implications for the user experience of doing so.

2. What will the overall management structure be? In other words, which agency or agencies will be responsible for the design, development, and operations of the Washington, DC 511 system?

Recommendation: We recommend that the Committee select an agency and an individual to take the lead on the project, and then form a Policy Committee to give guidance on policy and day-to-day operational issues.

3. Which agency will take the lead for the various functions (securing funding, leading the procurement, approving deliverables, operating the system, etc.)?

Recommendation: This issue can be addressed by the Policy Committee.

4. Which agency or set of agencies will be responsible for data quality and the ongoing accuracy of the phone numbers to which callers may be transferred to (such as transit agencies)?

Recommendation: This issue can be addressed by the Policy Committee.

5. Will the system include speed and/or travel times on the phone and / or web page and, if so, how?

Recommendation: We recommend including all available information on both the phone, if practical, and the web.

6. Who will be in charge of marketing and what is the expected contribution from partners for in-kind marketing (such as signs on buses)?

Recommendation: We suggest that members of the Committee and allied agencies work to ensure that someone involved in the project—either through the 511 contractor, a separate consultant, or an employee of one of the agencies—have experience in marketing consumer products. In addition, in order to leverage scarce funds, we urge the Committee to get as much in-kind marketing as possible.

7. Will there be any private sector involvement (tourism, etc.)?

Recommendation: This will depend in part on whether the system is an independent system or part of the Virginia system. We recommend, at the least, building the 511 system in such a way so as to not foreclose private sector and other public sector support and involvement.

5.3 Summary of Costs

The following table summarizes the cost estimates for developing and operating the Washington, DC 511 system. Cost drivers are discussed throughout the document, and more detail is provided in Section 5.11.

Figure 5.1 – Summary of Cost Estimates

	Independent System		Extension of 511 VA	
	Low	High	Low	High
Startup	\$1.0M	\$2.4M	\$0.4M	\$0.8M
Annual	\$0.4M	\$0.5M	\$0.3M	\$0.4M

5.4 511 System Implementation

5.4.1 Introduction and General Guidelines

To establish and sustain 511 services, it is necessary to clearly articulate the general approach to how resources will be used. For the DC area’s 511 system, we recommend the following principles:

- All landline calls for the basic service should be no more than the cost of a local call to the user
- The public sector anticipates supporting most or all of the basic service costs as described in Section 5.11
- Sponsorship and advertising on basic services can be used to defray the costs to the maximum extent possible
- Self-supporting or revenue generating “optional” content is possible but should not be relied upon to fund the system

5.4.2 Population in Coverage Area

The coverage area for the DC 511 system is shown in Figure 4.1. The roadways listed in Appendix A include over 350 directional miles of interstate highway and over 500 arterial

directional miles inside the Capital Beltway alone. The areas covered and associated populations¹ are listed in Figure 5.2.

Figure 5.2 – National Capital Region Population

Area	Population
District of Columbia	563,384
Virginia	
Arlington County	187,873
Fairfax County	1,000,405
Loudoun County	221,746
Prince William County	325,324
City of Alexandria	128,923
City of Fairfax	22,031
City of Falls Church	10,485
City of Manassas	37,166
City of Manassas Park	10,990
Maryland	
Montgomery County	918,881
Prince George's County	838,716
Frederick County	213,662
Charles County	133,049
Total Population of Coverage Area	4,612,635

5.4.3 Summary of Content

Figure 5.3 summarizes the recommended content. There are many other data sources available, but in the interest of maximizing the investment, we recommend focusing on those that will provide the greatest return. The full results of the investigation into content available in the DC area are included in Appendix C. Also included in Appendix C is a table developed in support of an October 2004 study of RITIS.

¹ Populations noted are 2003 estimates by the U.S. Census

Figure 5.3 – Summary of Recommended Content

	Content	Providing Agency	Geographic Coverage	Phone, Web, or Both
Roadway Information²	Construction	Maryland DOT	Maryland highways	Both
	Construction	Virginia DOT	Virginia highways	Both
	Congestion	Maryland DOT	Maryland highways	Web, Possibly Phone
	Speed Info	Montgomery County, MD	Major arterials	Web, Possibly Phone
	Road Closures, Delays, Incidents	Maryland DOT	Maryland highways	Both
	Road Closures, Delays, Incidents	Virginia DOT	Virginia highways	Both
	Incidents	District DOT	Washington, DC streets	Both
	Incidents	City of Fairfax	Major arterials	Both
	Weather-related Road Information	National Weather Service	Entire Region	Both
Transit Information	Service Disruptions	All transit agencies	Washington, DC Metro Area	Both
	Real-time tracking; schedules, fares, etc.	Virginia Railway Express	Washington, DC Metro Area	Web
	Schedules, fares, etc. Incidents.	WMATA	WMATA service area	Web
	Schedules, fares, etc.	Other transit agencies	Varies	Web
Optional Content	Special Events	Multiple agencies	Varies	Both
	Roadway Security Measures and General Security Alerts	Police, Homeland Security	Varies	Both
	Airport Info: Parking information, ground transportation	Metropolitan Washington Airport Authority; BWI	Airports	Both
	AMBER Alerts	Police	Entire Region	Both
	Tourism Information	Various	Varies	Both

² Only those roadways identified as covered in the Conceptual Design will be included.

5.5 Data Fusion

Data fusion is the process by which the content described above is made ready for dissemination over the 511 telephone system and the web page. The data fusion system takes all of the various inputs and ensures that they are in a format that can be recognized by the 511 phone server and the web server. In the 511 Virginia system, this process has three steps and is illustrated in Figure 5.4.

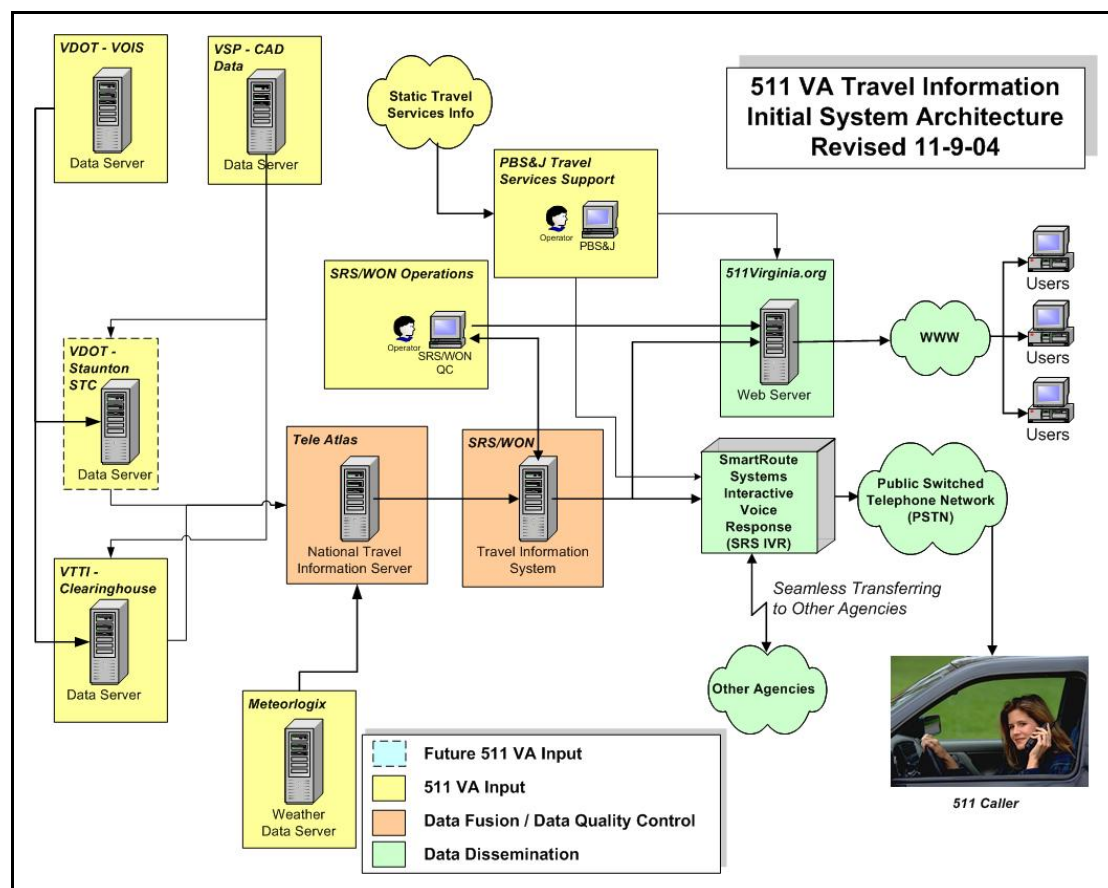

Figure 5.4 – 511 Virginia System Architecture

First, Virginia Tech Transportation Institute (VTTI) receives data from VDOT Virginia Operational Information System (VOIS) and the Virginia State Police (VSP) Computer Aided Dispatch (CAD) System and standardizes those data. Virginia Tech then sends a data stream to Tele Atlas, who fuses the Virginia Tech traffic data with weather data from Meteorlogix. Tele Atlas then sends the data stream to Smart Route Systems (SRS/WON), who fuses it with its operations data and prepares it for dissemination over the 511 system and the 511Virginia.org web page.

The specifics would likely be different, but the Washington, DC system will have to perform similar functions to make information available over 511 and the Internet. Depending on the number of agencies for whom data will be required and on whether any other system (such as RITIS) could be used, the data fusion task might be more complicated for the Washington, DC area than for the Virginia statewide system.

The National Capital Region 511 system will be compliant with and conform to the regional architecture utilized in the metropolitan area. An initial system architecture is shown in Figure 5.5.

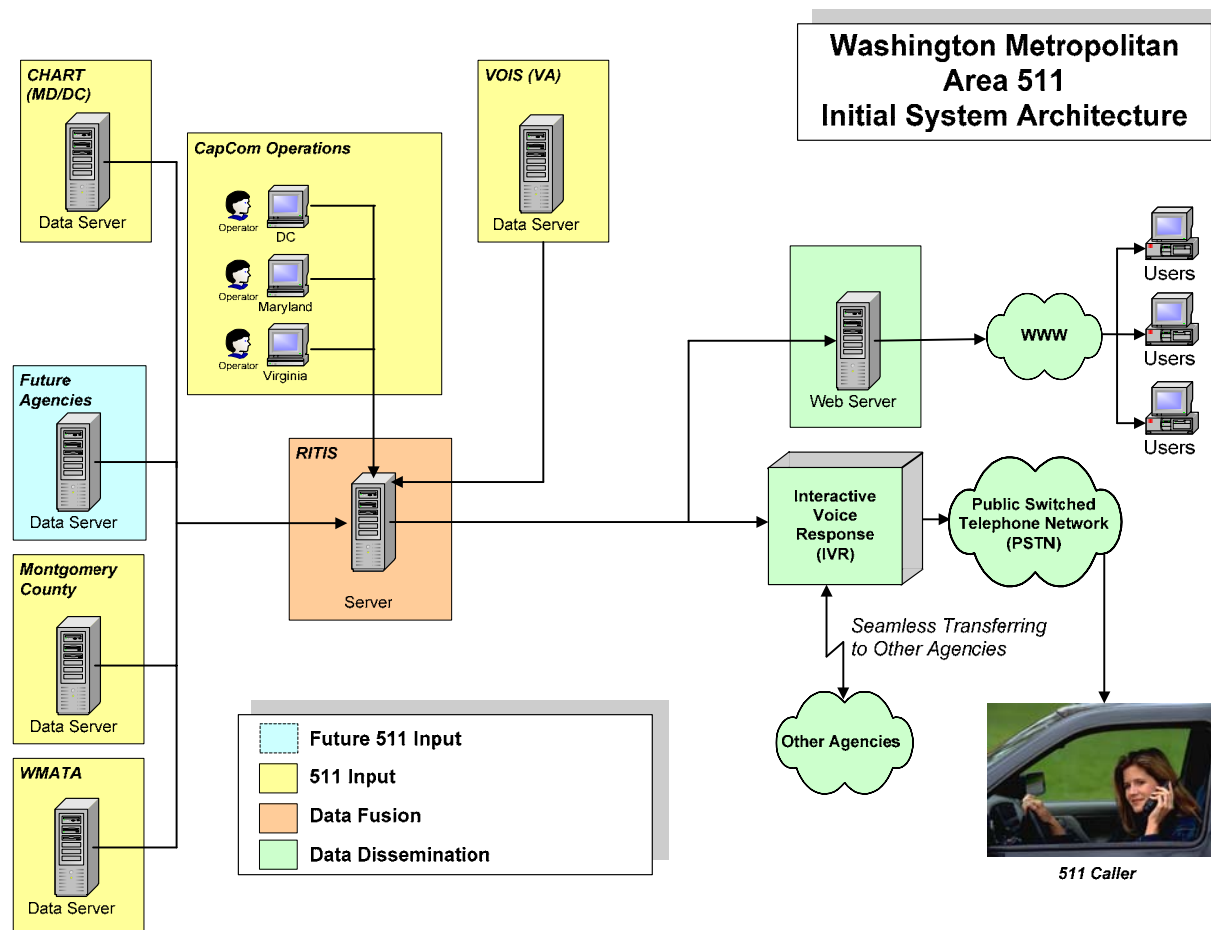

Figure 5.5 – National Capital Region 511 System Architecture

5.6 Telephone System Sizing

A discussion of the number and architecture of phone lines must begin with the issue of call volume. Call volume is primarily a function of population, the quality of the data, and marketing. The expected call volume during both average usage periods and during usage spikes

drives the number of lines or ports required. This, in turn, drives much of the cost for the system.

An effective way to estimate the size of a 511 system is to study lessons learned from other deployers of both 511 systems and other types of telephone based traveler information services. Figure 5.6 lists six metropolitan areas that have 511 traveler information systems or, in the case of Boston, a widely-used non-511 system. For each system, the table shows whether the system is local or network-based, the peak port usage, and the average calls per month, the peak month usage, the peak day usage, and population.

Figure 5.6 – Metropolitan 511 Systems

Metropolitan Area	On-premise or Network	Peak Port Usage	Average Calls/Month	Peak Month Total	Peak Day Total	Population
Boston	On-premise	186 ³	500,000	630,000	50,000	5,800,000
Cincinnati /N. Kentucky	Network	27	50,691	88,360	14,608	2,000,000
Orlando	Network	133	106,026	178,023	19,392	1,800,000
South Florida	On-premise	144	129,164	211,648	21,345	4,800,000
Tampa	Network	N/A	52,203	83,106	14,656	2,500,000
San Francisco	On-premise	143	201,035	385,845	30,241	6,900,000

Based on the data from existing metropolitan 511 systems, we estimate that the DC area 511 system, serving a population of over 4.6 million, initially will receive approximately 100,000 calls per month. This suggests a need to handle approximately 50 simultaneous calls on an average day and approximately 140 simultaneous calls during usage spikes.

Among deployers who have chosen to use an in-house solution, the issue of call acceptance, or the number of simultaneous calls that are able to get through without the caller reaching a busy signal, is a critical one. One benefit to contracting with a network provider (as is our recommendation) is the ability of the provider to share ports among clients, so that one client does not have to pay ongoing costs for ports that are used only during emergencies or other instances of heavy call volume. That being said, however, it is important to understand that it is not essential that callers never get busy signals. The current Guidelines recommend building a system so that the 90th percentile of demand is met; in other words, at least 90% of the time, all calls should get through.

5.7 Website

People seeking travel information are growing increasingly technology-savvy, and have come to expect that information pertinent to their trip be available on the Internet. Websites offer a wealth of pre-trip information to the potential traveler, and the availability of accurate, reliable

³ Boston's system has a total of 186 ports, which allows the system the capacity to handle over 50,000 calls a day.

data is critical to many users. A co-branded 511 website, while not currently covered under the Guidelines, is often considered a standard part of a complete 511 service. Because there are existing traveler information web sites in the area (including Maryland's CHART project at <http://www.chart.state.md.us/> and WMATA at <http://www.wmata.com/>, for example), it may not be essential to develop a co-branded 511 web site for the Washington, DC area. Alternatives include not building a web page at all; partnering with existing traveler information web sites; or building a 511 web site that only links to existing web pages but has no original content or services.

If a website is developed, it must be user friendly, offering basic information at a glance, as well as more detailed information deeper in the site. The task is not easy; Washington, DC is a well traveled, often-visited destination, and is dense with heavily-traveled interstates, arterials, and a robust multimodal transit system.

5.7.1 Content

General

The content available on a co-branded DC 511 website will be similar, if not identical, to the information offered via the 511 phone system. A website would offer information on roadway conditions, public transportation, tourism, context-sensitive help, and information on or links to neighboring traveler information websites. In addition, optional content recommended for inclusion on the phone system would be present on the website as well. The data disseminated via the DC 511 website will be generated from the same data streams that feed the phone system, thus resulting in a high level of commonality between the phone and website. In addition, if the Committee decides to make it available, speed and congestion information would be available on the web, as would be connections to transit information currently available at transit agency web sites.

Traffic Cameras

Traffic cameras are a critical part of a traveler information website and will be a significant offering of the DC 511 service. In addition, cameras are one of the elements available to users only online and not via 511. Trafficland, (www.trafficland.com) is the most sensible partner to seek in the provision of traffic cameras for the DC area. Trafficland aggregates traffic camera images from a variety of public and private sources to offer over 75 cameras in the coverage region. Still shots and short bursts of traffic video are available, depending on the capability of each individual camera. A hyperlink to the TrafficLand website from the DC website would be a low cost way to offer users access to camera images. It would also be possible to offer access to TrafficLand's cameras via a "Traffic Cameras" tab, which could open the application within a DC 511 frame. A more elegant (and more expensive) option is to offer the user a "camera map" of the region, providing a map of clickable camera locations. Each camera icon would open the current image or video of the chosen camera location. These issues will be raised and resolved in the system requirements definition and design process.

5.7.2 Design

The centerpiece of a traveler information website is an interactive map of the coverage area, including icons with event information and/or color-coded congestion, with accompanying textual list of events. Some deployments feature maps created using a GIS database and others are hand-drawn to better serve a region's particular needs. An interactive map lets the user determine at a quick glance the area covered with the service, and allows the user to get graphic information related to the desired route or area.

On the website, it is not necessary to segment roads as it is with the phone system. While the length of one entire road within the coverage area (such as the Capital Beltway) will often have an overwhelming amount of information to provide over the phone, the same is not true when dealing with an interactive map. A user can glance at an entire roadway and simply choose the area desired. An interactive map will let the user chose the desired area and receive information available for that road/corridor/region.

5.7.3 Domains

If the Committee decides to develop a web site, the lead agency should secure a short list of website Uniform Resource Locators (URL) or addresses, with "511" in the title. If more than one domain is purchased and implemented, each address can simply re-direct the user to the DC 511 website. Website addresses available at the time of this publication include:

- www.metrodc511.com (org/net)
- www.dcmetro511.com (org/net)
- www.511metrodc.com (org/net)
- www.511dcmetro.com (org/net)
- www.washingtondc511.com
- www.511washingtondc.com
- www.511dc.net
- www.dc511.net

Additional desired domains that are currently owned are not necessarily unavailable. "Cyber-squatters" are individuals or businesses that register and hold on to URLs that may be needed by other organizations. These squatters try to sell the name to the organization willing to pay for it. However, courts have in the past frowned upon such practice, and unless the squatter can prove a claim to the intellectual property that would necessitate continuing to own the name, the squatter often has to turn over ownership of the URL.

5.8 Procurement and Operations

5.8.1 Procurement Approach and Business Model

As the Conceptual System Design discussed, the prospects of any business model other than one that relies on government funding are extremely unlikely. Consequently, our recommendation is that the procurement be designed to lead to a fee-for-services contract with a 511 contractor. The details of the procurement approach largely depend on whether this system is included as part of the Virginia system or it is a separate system; where appropriate, the stages shown below highlight where decisions need to be made. The time frame for these activities is shown in the schedule in Section 5.10.

- Pre-Procurement
 - Identify Funding
 - Designate Lead Agency
 - Designate Project Manager from lead agency
 - Form Oversight Committee to provide input on strategy and policy; procurement oversight; oversight of system development and daily operations (including software development, telecommunications, marketing, and so on)
 - Evaluate Options, including:
 - Expand VDOT Contract with task order for DC 511
 - Procure separate system; develop procurement materials in-house
 - Procure separate system; hire consultant to assist with the procurement
- Contract
 - Develop specifications and/or functional requirements for 511 (either in-house or with consultant assistance).
 - Prepare a Request for Proposals (RFP) for a fee-for-services contract to develop, operate, and maintain the Washington, DC 511 system. Include an initial term and then options to renew.
 - Conduct procurement, select a contractor and enter into the contract.

5.8.2 Components of the 511 System

The contractor, through the DC 511 procurement, will perform operations functions 24 / 7 / 365 including content management, operations and maintenance of the phone service, website, data fusion engine and any optional services agreed to.

511 Telephone System

The contractor will be responsible for: the content on the phone system; maintenance of the phone system menu; transfers to other agencies; providing sufficient capacity to answer all calls to 511 at least 90% of the time; and other tasks related to making sure that 511 is accessible to as many callers as practical.

Content

The contractor will gather information from other agencies to populate the transit and airport messages, operate the data fusion system and establish methods to obtain information from adjacent regions. A key question will be whether the contractor will be responsible for seeking out the information or whether the agencies will be responsible for alerting the contractor to changes in the information they provide. The operators also will be monitoring the quality of information provided by Committee agencies and alert the 511 project manager when persistent issues pertaining to data quality occur.

Menu Structure

The 511 system will allow for minor changes in the phone menu structure or composition within four hours of the request. “Minor” changes are defined as:

- Disable an existing prompt
- Replace existing prompt with a new prompt
- Change in transfer numbers

The region’s stakeholders may identify other minor changes.

Call Transfers

The 511 contractor will work with the outside agencies that the Committee determines to enable a call transfer, ideally in each direction, between the agencies. When the 511 system transfers a call to an outside agency, it is anticipated that the call, after connecting, will be dropped from the 511 system, opening the port to allow other incoming calls. The 511 contractor will work with all outside agencies to determine the most cost efficient plan for transferring calls between the 511 system and the agency’s system. Where possible, the contractor will attempt to put in place a call transfer program that terminates the charges to the DC 511 system once the call transfer is complete. Before a call is transferred, the user should be informed of the business hours of the organization receiving the call. An additional option is to set up the system with “attended transfers,” in which a caller is returned to the 511 system if the number to which the call is transferred does not answer, is busy, or is otherwise unavailable.

The services to receive a call transfer include:

- Virginia’s 511 services (unless this system is implemented as part of the 511 Virginia program)
- Statewide road conditions and construction information in Maryland, if appropriate
- Public transportation services
 - WMATA Customer Service Center (Note that WMATA would receive the bulk of transit calls, as they have information about all local providers’ services, significant staff dedicated to customer service, and an automated trip planning feature)

- Alexandria DASH
- Arlington Rapid Transit
- Fairfax Connector
- Fairfax CUE
- Falls Church GEORGE
- Loudoun County Transit
- Maryland Rail Commuter Service (MARC)
- Metropolitan Washington Airports Authority
- Montgomery County Transit – Ride On
- PRTC (serving Prince William Co.)
- TAGS
- TheBus (Prince George's County)
- VRE

When Maryland's 511 service comes online, the 511 contractor will work to enable call transfers between this system and the Washington, DC 511 service. The possibility to do data exchanges / transfers with other services also needs to be determined.

Call Spikes

Per the 511 Guidelines, 511 systems should be able to answer all calls 90% of the time. There are different methods—sharing ports, queuing callers and so on—to achieve this. It will be the contractor's responsibility to do so.

511 Availability

The contractor will be responsible for monitoring the region's telecommunications providers to inform the Lead Agency of any who are not making 511 available to their customers. The 511 contractor should also perform the necessary carrier coordination to ensure that all carriers translate calls to 511 appropriately with the Lead Agency paying the carriers directly for the translation.

The Lead Agency may also wish to direct the contractor to explore having payphone providers in the coverage area offer access to 511 as well, although there are likely significant cost implications to this option. Currently, no operational 511 service includes comprehensive access from payphones.

The contractor will also be required to make users aware of PBX programming information on the 511 website or through other means, so that callers using a PBX will be able to call 511.

As mentioned in the 511 Guidelines, the Americans with Disabilities Act and environmental justice issues need to be considered in making 511 available to the public.

Traveler Information Website

The co-branded website that is developed as part of this deployment should have continuously updated information including:

- The basic content described for the 511 phone system
- AMBER and public safety alerts
- Frequently Asked Questions (FAQs) about 511
- Instructions on using the telephone service
- Hyperlinks to specialized construction-related websites, if any
- Hyperlinks to the websites of all public agency partners and to private sector partners
- PBX dialing programming information

The 511 system will allow for minor changes in the website and its composition within four hours of the request. “Minor” changes are defined as:

- Change a hyperlink
- Enabling or disabling banner message
- Changing banner message
- Moving placement of banner message

The region’s stakeholders may identify other minor changes.

5.8.3 Roles and Responsibilities

Perhaps the key issues facing the Committee relate to deciding who will be responsible for the day-to-day operations of the 511 telephone service and the allied website. The key areas of responsibility will be the following:

- Oversight of the 511 Contractor (including paying invoices, ensuring contractual compliance, etc.)
- Data quality assurance and control
- Oversight of the day-to-day functioning of the phone and website
- Marketing decisions
- Decisions on system upgrades and improvements

It is our recommendation that whichever agency leads the procurement effort also be responsible for all aspects of the system except, perhaps, for data quality.

There are various options, as follows, for ensuring data quality. For these purposes, the term “data quality” also includes the accuracy of the telephone numbers that are used for call transfers and the hyperlinks on the web page. The options are:

- The agency responsible for contractor oversight can also be responsible for monitoring data quality. Advantages of this approach are that the agency most invested in the successful operation of 511 is also the agency responsible for overseeing data quality, one of the key drivers of public acceptance. Disadvantages are that data monitoring is time consuming and sometimes requires special expertise. Additionally, agencies sometimes have little leverage over other agencies.
- Each agency can be responsible for monitoring the accuracy of its own data. The advantage of this approach is that the agency most knowledgeable about the data is responsible for ensuring the quality. The key disadvantage is that the diffuse responsibility can mean, in the end, that no one is in charge of overall data quality.
- A separate consultant can be procured specifically to monitor data accuracy. The advantage of this approach is that it allows a consultant to use its expertise to track data quality. The disadvantage is that it is more costly than the other approaches.

5.8.4 System Expansion / Upgrades

The 511 service will evolve from its launch on Day 1 and should be designed to be flexible and expandable as consumers' expectations for 511 evolve and grow. The 511 procurement should include provisions to modify menus, expand capacity, etc. The Lead Agency will work with the contractor after the initial implementation to determine upgrade plans.

These enhancements could include:

- Additional Data, should new sources become available
- Commercial Services / Services for a Fee
- Bike / Pedestrian Information
- Alternate Route Information
- Itinerary Planning
- Maintenance Information
- Parking / Park and Ride Information
- Train Information
- Bilingual Information
- Directions
- Additional Transit Agency Information / Transfers

The contractor will see that enhancements to the system do not degrade overall system performance and accessibility. The enhancements and expansion of the system must be carefully planned and designed so as not to disrupt normal system operations.

5.9 Marketing

Conceivably, the Committee could spend as much to market the 511 services as it will to build, operate and maintain the 511 system. On the other hand, many services operate effective statewide 511 marketing programs for \$100,000 to \$250,000 per year. The Committee can benefit from the experiences of other 511 deployers to “get the word out” about the availability of 511 in the Washington, DC area. The 511 Deployment Coalition has a variety of tools available to assist deployers with their marketing efforts.

In addition, the various agencies on the Committee have marketing professionals on their staff in Public Information Offices who know transportation and public awareness and the contractor should also have this competency. The goal of the 511 Marketing Plan will be cost-effective and resourceful approaches to create and maintain awareness, and to continually increase usage. Marketing the 511 services will require close cooperation between the contractor and the agencies on the Committee.

5.9.1 Washington, DC 511 Marketing Plan Background

511 is a true consumer service and effective marketing efforts are needed to ensure the success of 511 systems and the Committee needs a contractor with experience working with transportation public awareness campaigns and consumer products. The 511 message needs to be delivered to target audiences in the most efficient and effective way. National studies show that travelers get travel information mostly from radio and television in the form of traffic reports, but websites are becoming more popular.

During the development phase of the project, the Committee and the contractor should develop the 511 marketing theme and plan the marketing efforts. Beginning with the system launch, the Committee and the contractor would work to generate awareness and educate the public about the information available on the Washington, DC 511 and how to access it through earned and paid media tactics. During the operational phase of the 511 system, the marketing campaign would ensure that the public continues to utilize the Washington, DC 511 services. Existing 511 services marketing efforts run the gamut from relatively low-cost efforts such as roadside signs to full-blown advertising and marketing campaigns. Today, 511 nationwide is still in the developmental stages and most travelers, even those who can access the service on a daily basis, do not know of its existence.

The communications about and messages focused on 511 need to continue to resonate with the public while 511 is available in the region. The Committee and the contractor should use the marketing plan to “get the word out” about the benefits and features of 511 services (telephone, website and possibly others) to travelers (commuters, truckers, through travelers and tourists) in the Washington, DC area. Beyond travelers, there are three other important audiences to target: agency staff; partner organizations – both public and private; and the media.

5.9.2 Goals

The primary goal of the 511 marketing plan is to create awareness and use of 511 for travel information. The marketing campaign leading up to the launch should establish a baseline measurement for awareness of 511 in the region and ask consumers what they think 511 entails.

5.9.3 Key Message

The key message of this campaign will be that Washington, DC's traveler information services – consisting of 511 information access via the telephone, website and other services, if applicable – provide easy and direct access to accurate, timely and reliable travel information.

5.9.4 511 Logo and Branding

AASHTO has registered a 511 logo that deployers, except one, utilize to market their 511 services. This logo has become the de facto 511 “brand” nationwide and the Committee should use it to co-brand the telephone, website and other services. By using 511 as its traveler information “brand,” the Committee will have a unified theme with consumers for all of its traveler information offerings.

Some travelers will immediately recognize the logo, and what it is associated with as Virginia has been using it for both the initial regional and statewide services.

5.9.5 Marketing Plan Activities

The following activities should be included:

- Research
- Theme Development
- Creation of Communications Materials
- Media Tours / Speaking Engagements
- Launch Event
- Advertising
- Direct Mail Pieces and Other Collateral Materials
- Monitoring of Marketing Effectiveness
 - Awareness
 - Satisfaction
 - Usage
- Marketing Plan Update

5.10 Schedule

Figure 5.7 illustrates the schedule for the procurement, development and launch of the Washington, DC 511 system. This schedule is based on the following assumptions:

- There will be a new procurement for the DC 511 system
- It will take at least seven months from the end of this Feasibility Study to make a go/no-go decision on developing a 511 system
- There will be no RFP for a consultant to assist in the preparation of the procurement materials.

Figure 5.7 – DC 511 Development Schedule

Task	Completion Date
Completion of Feasibility Study	May 31, 2005
Designate Lead Agency/Project Manager	June 30, 2005
Identify Funding	July 31, 2005
Develop Policy Group and Working Group	September 30, 2005
Decision to Procure 511	October 31, 2005
Specifications/Requirements	December 15, 2005
RFP Issued	January 31, 2006
Proposals Received	March 31, 2006
Consultant Selected	May 31, 2006
Contract Executed	June 30, 2006
511 Launched	February 1, 2007

Note that the total time would be significantly shorter if the system were done as part of 511 Virginia. Instead of starting from scratch, doing the work as part of the 511 Virginia system would leverage the work done already for data fusion and for the 511 system itself. The primary effort required at that point would be to decide which new data to include and modify the phone system to include options for Washington, DC. In addition, because one option for the work would be a task order under the existing VDOT contract, there would not have to be a procurement. That option alone would save the six months needed to develop an RFP, wait for proposals and select a contractor.

5.11 Estimated 511 Costs

The costs associated with designing, building, operating and maintaining a 511 system are extremely varied. The 511 Deployment Coalition has published a report on the costs and benefits of 511, available at http://www.deploy511.org/docs/511_Value.pdf.

This section includes two parallel cost estimates for the Washington, DC area 511 system, one for a independent regional system and one for an add-on to the existing 511 Virginia statewide

system. Each one includes “high” and “low” estimates. In addition, there are separate estimates for the startup period costs (Figure 5.8) and for the ongoing (operational and maintenance) costs (Figure 5.9). The costs are further broken down into the following categories:

- **Labor** – All personnel (Full Time Equivalents (FTEs), part time workers, Information Technology (IT) staff dedicated to 511, man-hours spent training staff on new procedures and equipment, consultants and vendors working on 511) fall within this category. The bulk of labor costs are generally realized during the design and implementation of 511; as the system becomes operational, the labor costs decrease. During the design and implementation phases, the responsible agency for 511 in DC can expect to dedicate a project manager and IT resources, and may hire a contractor to assist in the early phases. Personnel may have to be trained on using new software and hardware.
- **Equipment** – Jurisdictions offering traveler information - on the Internet, via phone or both - generally need to invest a significant percentage of an implementation and maintenance budget on hardware and software. Contracting with an outside application provider to host and manage the hardware and equipment may cause the responsible agency to realize some greater costs up front but may significantly reduce long term maintenance and operational costs.

There are several ways to architect the flow of data to a network provider. Various data streams can be directed to the provider, or the agency responsible for DC 511 can create a central clearinghouse of data. It is possible that some day, the data available through the RITIS could serve as a single clearinghouse of information for 511. Regardless, some fusion will need to take place to ensure that the systems processing those data are compatible with the 511 phone system. In addition, a new co-branded website should be developed, offering information similar to, if not the same as, that offered via the phone system. Website costs include design, monthly hosting fees and upgrades.

- **511 Content Upgrades** – The 511 Deployment Coalition has published Guidelines regarding recommended basic, and suggested optional, content that should be considered during the design and implementation of a 511 service. The Washington, DC area benefits from a wealth of agencies collecting and disseminating myriad traffic, transit and tourist information, and it is our assumption that no additional content will be created specifically for 511. We have included a place-holder cost for this line item in the event that it is determined that a relatively minor investment could provide significant improvements in content.
- **Telecommunications** – One principle guiding the deployment of a national 511 is a seamless, transparent telecommunications structure. In short, the call goes through and the call gets answered. Carrier tariffs, call switching fees, central office programming and cell tower programming fees vary widely from one provider to the next. ILECs on

the Virginia side of the District have been contacted and are implementing 511 in the region; costs for the majority of those carriers have already been settled.

There are two ILECs in the state of Maryland: Armstrong Telephone Company and Verizon. Verizon is currently in negotiations with VDOT regarding the cost of programming their Virginia central offices. The same kind of negotiation is likely to be necessary for a DC region deployment. Armstrong Telephone Company operates one central office in Maryland, and while this carrier has no tariff on file for N11 call switching, they are expected to ask for the same per-central office cost as Verizon.

There are five major wireless carriers (Verizon, Cingular / AT&T Wireless, Sprint PCS, Nextel and T-Mobile) and many smaller wireless carriers with whom to coordinate routing of 511 calls. Due to the unique characteristics of the region, i.e. the spanning of two states and its proximity to another large urban area, the issue of wireless carriers programming their cell towers to properly route 511 calls is a critical one. Most of the wireless carriers do not charge a fee for cell tower programming, with the exception of Cingular. Cingular has a standard charge of \$400 to program a state or region, and between \$25 - \$100 per tower. With more than 100 towers in the DC area, the implementing agency can expect to be charged the \$25 rate.

Should Maryland DOT ultimately create an independent system, the issue of call transfers to Virginia's statewide system, a Maryland statewide system, a Baltimore regional system or a Pennsylvania system, must be addressed.

- Marketing – Successful marketing of 511 involves many factors, not the least of which is highway signage. Evaluations of 511 implementations show that the traveling public often first learns of 511 from highway and arterial signage. The 511 Guidelines suggest that roadway signs be installed an average of every 10-12 miles on the highway. However, as DC is a highly urbanized region, a significant portion of the signage purchased and installed should be on arterials.

Radio and television advertisements, brochures available online and at tourist information centers, can also be components of a successful marketing campaign. The costs vary widely, but an urban area such as DC, as a major media market, may encounter higher than average costs for this type of marketing.

To summarize, creating an entirely new, independent system would cost significantly more than would implementing this system as part of the 511 Virginia system. There are economies of scale, and previous research, design and implementation that could be leveraged by using the 511 Virginia system. For instance, a significant amount of time and money has already gone into designing and implementing the architecture for data flow within and external to the 511 Virginia system. Creating an additional “section” of information, i.e. DC coverage, would allow the lead agency to benefit from a proven architecture already in place.

Coordination with telecommunication carriers provides an additional opportunity to leverage existing work. Verizon is the dominant landline provider in the DC area, and covers a large amount of Virginia as well. As of the date of publication of this study, negotiations are being finalized by VDOT with Verizon to secure a mutually-agreeable fee structure. Should the lead agency in DC choose to implement on its own, the leverage gained from these negotiations would be lost, and the labor costs to actually participate in these negotiations would be incurred again.

Figure 5.8 – Estimated Startup Costs

Service	Independent System	Extension of 511 Virginia
Labor		
Network host application development, engineering, IVR license purchase and implementation	\$450,000 - \$850,000	\$50,000 - \$95,000
Project management FTE	\$85,000 - \$130,000	\$85,000
Training sessions for central and field personnel	\$35,000 - \$75,000	\$35,000 - \$75,000
Professional consulting for implementation phase	\$0 - \$250,000	N/A
IT staff	\$65,000 - \$120,000	\$7,000 - \$15,000
Equipment		
Data fusion development	\$250,000 - \$500,000	\$50,000 - \$95,000
Website design	\$25,000 - \$150,000	\$25,000 - \$150,000
Communications upgrade to feed network provider	\$17,000 - \$25,000	\$17,000 - \$25,000
511 Content Upgrades	\$0 - \$70,000	\$0 - \$70,000
Telecommunications		
Potential reprogramming of existing towers and central offices ⁴	\$0 - \$45,000	\$0 - \$45,000
Verizon Tariff ⁵	\$7,500	\$7,500
Armstrong Telephone Co. Tariff ⁶	\$500	\$500
Wireless carrier implementation costs	\$3,750	\$3,750
Marketing	\$150,000 - \$250,000	\$150,000 - \$250,000
Total Estimated Startup	\$1,088,750 - \$2,465,000	\$430,750 - \$820,000

⁴ Most carriers will do this for free, or a nominal fee. Cingular and Verizon charge for the service, however, and the exact amount must be negotiated.

⁵ In Virginia, Verizon is currently asking for \$500 per central office. While negotiations are taking place as of the publication of this document, this figure is being used for the purposes of calculation. Verizon has approximately 15 central offices in the proposed DC coverage area.

⁶ Armstrong Telephone Company operates one central office in Maryland.

Figure 5.9 – Estimated Annual Costs

Service	Independent System	Extension of 511 Virginia
Telecommunication charges (toll-free backbone) ⁷	\$40,250	\$40,250
Ongoing Maintenance of Telecom Equipment	\$10,000 - \$20,000	\$10,000 - \$20,000
Network Provider	\$85,000 - \$120,000	\$45,000 - \$65,000
Marketing	\$150,000 - \$200,000	\$150,000 - \$200,000
Professional consulting for operations and maintenance	\$65,000 - \$115,000	\$30,000 - \$50,000
Internal Staffing	\$85,000 - \$130,000	\$40,000 - \$65,000
Total Annual Estimated Costs	\$435,250 - \$585,000	\$315,250 - \$400,000

⁷ Assuming 115,000 minutes monthly at an average of 3.5 cents per minute

6. RITIS, CapCom and 511 Implementation

Based on interviews with stakeholders and Regional Integrated Transportation Information System (RITIS) project research regarding data available for 511, there is sufficient data in the Washington, DC metropolitan area to provide reliable, useful information to travelers in the region. The Study team reviewed the Data Sources document dated October 2004, developed by PB Farradyne, in supporting the RITIS project. RITIS will be a primary source of information for dissemination to travelers by the Washington, DC metropolitan area 511 service.

With RITIS data identified as a primary source, more investigation of RITIS was warranted. Eventually, RITIS will be administered by CapCom – a regional operating organization modeled on Transcom (<http://www.xcm.org>) in the New York City metropolitan area – and below are further details on RITIS, CapCom and 511 implementation in the region which are of interest to the Committee.

6.1 RITIS Background

The RITIS system will be an integration of existing transportation information and management systems in Virginia, Maryland and the District of Columbia. RITIS incrementally integrates data from the existing Transportation Management Centers and their associated information systems initially building over a three-year period with specific objectives and deliverable items for each year. Currently, there is no effective method for automated information exchange of transportation system data between the major transportation agencies in the region.

The RITIS project integrates the existing regional transportation management systems with a real-time regional data fusion engine and a regional data archive. RITIS takes regional data and provides fused real-time transportation information showing the status of the transportation network. This information shall be used to support transportation management and traveler information applications. When complete, RITIS will consist of one or more databases of real-time transportation system information and archived data designed to support three major functions:

1. Provide real-time transportation-related data to transportation agency personnel in the Washington, DC metropolitan area
2. Provide data to the traveling public, in this same area, via a website
3. Provide a data archive of transportation-related data to transportation agency personnel in the Washington, DC metropolitan area

The RITIS database is currently under development at the University of Maryland Center for Advanced Transportation Technology Laboratory (U MD CATT). Phase One of the project entails integration of data from five sources in the region:

1. Maryland State Highway Administration (MD SHA)
2. Virginia Department of Transportation (VDOT)
3. Washington DC Department of Transportation (DDOT)
4. Montgomery County, MD (MCTMC)
5. Washington Metropolitan Area Transit Authority (WMATA)

Phase Two is “Prototyping” which will take five months (estimated completion January 2006) and the final phase is “Full Operation” which will take 12 months (estimated completion January 2007).

As of publication of this document, there is not a large quantity of data in the RITIS database; most of the data is from MD SHA and DDOT (see Figure 6.1 for conceptual RITIS data flows). VDOT information will be incorporated once that agency’s new traffic management software is online. VDOT will ultimately provide a larger quantity of detector data than MD SHA due to their data refresh rates for detector data (1 minute and 5 minutes, respectively) and larger number of deployed sensors.

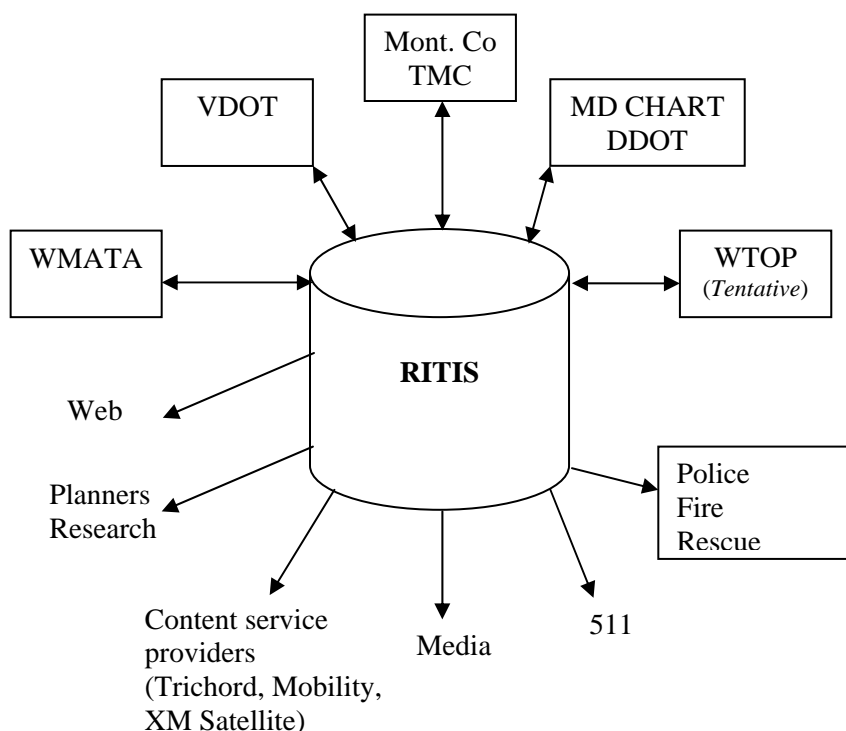

Figure 6.1 – RITIS Data Flow Concept Diagram

It has always been the plan for RITIS to support a regional 511 system in the Washington, DC Metropolitan area. How broad this support will be during the initial phase remains to be seen. Since the data needs of a regional 511 would be broader than the data that is planned for Phase One; additional data sources may be necessary, depending on the deployment schedule for the regional 511 system. This is especially true of transit data. Phase One includes only transit information from WMATA and major components of its information may not be contained in the RITIS Phase One database. Other transit data that is utilized by a large number of commuters in the region will not be included in Phase One (VRE and MARC for example which could be call transfers from the 511 service).

Currently, the RITIS database and real-time regional data fusion engine are under development at the U MD CATT Lab. Phase One of the project entails integration of data from the five major sources in the DC metropolitan area previously mentioned. Phase One is scheduled for completion by September 2005. At this time, Phase Two data sources have not been determined. The plan is to determine future data sources upon successful completion and evaluation of Phase One.

Once the Phase One RITIS system is complete, the plan is to transfer the system to the CapWIN facility. The reason for this is that U MD CATT does not currently have the backup power and redundant network infrastructure necessary to guarantee 24 / 7 / 365 service availability.

Monies for RITIS development were put aside before the events of September 11. The lessons learned in the Partners in Motion project have been applied as well. MD SHA is the lead agency coordinating development of RITIS which, upon its completion, will be administered by CapCom – an independent entity whose name is subject to change as of publication of this document.

6.2 CapCom Background

CapCom will be a single entity that will undertake the role of facilitating operational coordination and collaboration among transportation agencies in the region. CapCom will implement a Center that will improve the management and sharing of incident-related transportation systems condition and impact information.

Funding from a variety of sources will be utilized by CapCom which will have a number of responsibilities. One of the major responsibilities of CapCom will be to function as a “watchman” of the information on the various transportation systems in the region as well as any incidents, which may not be transportation related, that can / will have a ripple effect on the transportation system.

CapCom will be the single entity to process information from a variety of sources in the District, Maryland and Virginia through RITIS. This information will be synthesized and a determination will be made by CapCom staff as to what information needs to be brought to the attention of

which agency, for the purpose of minimizing negative impacts to the region's transportation system. Its role is strictly advisory; CapCom staff will have the most complete "picture" of the regional transportation system and will notify affected entities of any situations which could have negative impacts on the transportation system.

CapCom will not be the authority on how to handle an incident, it will not direct any agency in terms of what actions should be taken, it will provide information to the agencies so that they can make decisions based on a much broader "picture" of the situation than just in the immediate area of the incident. CapCom will anticipate any ripple effects that could occur and facilitate minimizing or eliminating them.

As of publication of this document, the architects of the CapCom organization (representing all major transportation agencies in the region) support utilizing RITIS data for dissemination via 511 with CapCom having the organizational responsibility for operating 511 in the region. As of May 4, 2005, funding in the amount of \$1 million for CapCom and RITIS data-related activities was made available as start-up funding and long-term funding is under exploration.

On a technical level, the Committee sees CapCom as the most desirable alternative for operating a National Capital Region 511 service, but no commitment to this has been made by any of the stakeholders. The success of the prototype effort underway for Phase One RITIS development will certainly have an impact on whether CapCom is the proper organization to operate and maintain a regional 511 system.

6.3 Regional Call and Cost Allocation Breakdown

VDOT serves travelers in Northern Virginia with its statewide 511 service and is committed to continuing to offer more coverage of roadways and more information through detection infrastructure already in place. In developing the statewide 511 system, VDOT has made an investment from which travelers in the region are already benefiting. With service availability since February 15, 2005, and without the kickoff of a concerted marketing plan, telephone numbers based in the Washington, DC metropolitan area (the 202, 240, 301, 410, 443, 571 and 703 area codes) accounted for 11.53% of all calls to 511 Virginia in February and 14.31% in March and 15.44% in April – see Figure 6.2.

	April-05	March-05	February-05
District of Columbia	1.82%	1.78%	1.72%
Maryland	4.19%	3.56%	2.84%
Northern Virginia	9.43%	8.97%	6.97%
All Other Areas	84.56%	85.69%	88.47%
TOTAL	100.00%	100.00%	100.00%

Figure 6.2 – 511 Virginia Regional Call Breakdown

With VDOT's prior investment, a Washington, DC metropolitan area 511 system's telephone service and website development costs would be shared by Maryland and the District of Columbia. VDOT does not expect the region to reimburse any costs related to the initial 511 Virginia system development. The 511 Virginia contract is valued at \$6.5 million for the first three years of system development and operations (includes approximately \$100,000 for telecommunications carrier coordination) with 2 two-year operational options available. VDOT also has a contract with VTTI for 511 quality control and evaluation at \$488,000 per year.

The Implementation Plan estimated costs: for an Independent System startup would range from \$1,088,750 – \$2,465,000 with annual operating costs of \$435,250 – \$585,000; and for an Extension of 511 Virginia startup would range from \$430,750 – \$820,000 with annual operating costs of \$315,250 – \$400,000. Maryland's and the District of Columbia's share of the estimated costs to develop the 511 system could be determined by mileage of roadways covered, population served or various other methods.

The Washington, DC metropolitan area 511 service will cover approximately 1,239 miles of roadway of which 95 are in the District and 644 are in Maryland. Allocating 12.9% of the 511 costs to the District and 87.1% to Maryland is shown in Figure 6.3.

<i>Mileage Basis</i>	Independent System		Extension of 511 VA	
	Low	High	Low	High
<i>Startup</i>	<i>\$1,088,750</i>	<i>\$2,465,000</i>	<i>\$430,750</i>	<i>\$820,000</i>
DC	\$139,995	\$316,958	\$55,387	\$105,438
MD	\$948,755	\$2,148,042	\$375,363	\$714,562
<i>Annual</i>	<i>\$435,250</i>	<i>\$585,000</i>	<i>\$315,250</i>	<i>\$400,000</i>
DC	\$55,966	\$75,221	\$40,536	\$51,433
MD	\$379,284	\$509,779	\$274,714	\$348,567

Figure 6.3 – Mileage Basis

The Washington, DC metropolitan area 511 service will serve approximately 4.6 million residents of which 563 thousand are in the District and 2.1 million are in Maryland. Allocating 21.1% of the 511 costs to the District and 78.9% to Maryland is shown in Figure 6.4.

Population Basis	Independent System		Extension of 511 VA	
	Low	High	Low	High
<i>Startup</i>	\$1,088,750	\$2,465,000	\$430,750	\$820,000
DC	\$229,874	\$520,450	\$90,947	\$173,132
MD	\$858,876	\$1,944,550	\$339,803	\$646,868
<i>Annual</i>	\$435,250	\$585,000	\$315,250	\$400,000
DC	\$91,897	\$123,515	\$66,561	\$84,454
MD	\$343,353	\$461,485	\$248,689	\$315,546

Figure 6.4 – Population Basis

Allocating 50% of the 511 costs to the District and 50% to Maryland is shown in Figure 6.5.

50/50 Allocation Basis	Independent System		Extension of 511 VA	
	Low	High	Low	High
<i>Startup</i>	\$1,088,750	\$2,465,000	\$430,750	\$820,000
DC	\$544,375	\$1,232,500	\$215,375	\$410,000
MD	\$544,375	\$1,232,500	\$215,375	\$410,000
<i>Annual</i>	\$435,250	\$585,000	\$315,250	\$400,000
DC	\$217,625	\$292,500	\$157,625	\$200,000
MD	\$217,625	\$292,500	\$157,625	\$200,000

Figure 6.5 – 50 / 50 Allocation Basis

These cost estimates can be shared by agencies in Maryland and the District of Columbia with information on the 511 system and do not necessarily have to be borne in full by DDOT or MD SHA. The cost estimates do not include management costs relating to a project manager, technical manager, database manager or other related agency staff.

7. Feasibility Study Recommendations

Of the four scenarios developed for the Implementation Plan, stakeholders determined that further investigation of the *Extension of 511 Virginia* and the *Independent System* should be considered as they both had near-term possibilities for deploying 511 in the region. The *No Build* option could be the direction for the region should funding and multi-agency cooperation not be available. The *Part of Maryland Statewide System* option was seen as a long-range type of option as Maryland has not begun planning for a statewide 511 service.

511 is feasible in the Washington, DC metropolitan area. Data and information is available to help travelers make better decisions. There will be a regional information sharing database with a standardized output and an organization willing to take on operational responsibility. The region has viable options for deploying 511 noted in the *Extension of 511 Virginia*, adding on to the existing 511 Virginia service, and the *Independent System* scenarios.

With RITIS data available from Maryland and the District in the early fall of 2005 and imminent funding decisions relating to the organization of CapCom, the Committee should make decisions relating to the *Extension of 511 Virginia* or the *Independent System* options, who will be leading the Washington, DC metropolitan area 511 effort and how to allocate funding.

7.1 Develop an Outreach Plan

The 511 Deployment Coalition is planning a media event, probably at the National Press Club, in conjunction with the five year anniversary of the designation of 511 in July 2005. This event presents an excellent opportunity for the 511 national leadership to meet with the region's policy and decision makers to discuss the value and benefits of 511 in the Washington, DC metropolitan area. PBS&J, which provides consultant support to the 511 Deployment Coalition, will work with the Committee to facilitate such a desired briefing, meeting or workshop.

The Transportation Planning Board (TPB) of the Washington Council of Governments was to be briefed on the 511 Feasibility Study at its April 20, 2005 meeting, but with the possibility of utilizing CapCom, its leadership asked to postpone this. The Committee should submit the 511 Feasibility Study to the TPB Technical Committee and brief the full TPB on the results of the Study at the earliest opportunity while coordinating with the CapCom leadership.

8. Appendix A – Washington Metropolitan Area 511 Facility List

DISTRICT OF COLUMBIA Interstates

I-295

I-395

Major Interstate Connectors

Canal Road

Connecticut Avenue

Constitution Avenue

East Capitol Street

Georgia Avenue

Independence Avenue

Massachusetts Avenue

New Hampshire Avenue

New York Avenue (US 50)

Pennsylvania Avenue

Rhode Island Avenue

South Capitol Street

Suitland Parkway

Wisconsin Avenue

DC 295

Bridges

South Capitol Street Bridge (Frederick Douglass Bridge)

Sousa Bridge

(See Maryland/Virginia)

VIRGINIA Interstates

I-66

I-95

I-395

I-495

Major Interstate Connectors

Dulles Greenway

Route 7

Route 28 (Centreville Road)

Route 123 (Ox/Chain Bridge Road)

Route 193 (Georgetown Pike)

Route 234

Route 236 (Little River Turnpike)

Route 243 (Nutley Street)

Route 244 (Columbia Pike)

Route 267 (Dulles Toll Road)

Route 400 (George Washington Memorial Parkway)

Route 620 (Braddock Road)

Route 645 (Stringfellow)

Route 3000 (Prince William Parkway)

Route 7100 (Fairfax County Parkway)

Route 7900 (Franconia/Springfield Parkway)

US 1

US 29 (Lee Highway)

US 50

Bridges

Virginia

Occoquan River (Woodbridge)

Virginia / DC Bridges

Key Bridge

Chain Bridge

Theodore Roosevelt Memorial Bridge

Arlington Memorial Bridge

14th Street Bridge

- George Mason Bridge
- Rochambeau Bridge
- Arland D. Williams Bridge

Virginia / Maryland Bridges

Woodrow Wilson Bridge

US 15 Bridge at Point of Rocks

Whites Ferry

American Legion Memorial Bridge

MARYLAND**Interstates**

I-70
I-95
I-270
I-295
I-370
I-495

Major Interstate Connectors

Baltimore-Washington Parkway
Clara Barton Parkway
Georgia Avenue
Germantown Road
Great Seneca Highway
Massachusetts Avenue
New York Avenue/ John Hansen Highway
Route 4 (Pennsylvania Avenue)
Route 5 (Branch Avenue/Leonardtwn Road)
Route 6 (Port Tobacco Road/Charles Street)
Route 17
Route 27 (Ridge Road)
Route 28 (Darnestown Road)
Route 40/70
Route 97 (Georgia Avenue/Roxbury Mills)
Route 185 (Connecticut Avenue)
Route 210 (Indian Head Highway)
Route 214 (Central Avenue)
Route 225 (Hawthorne Road)
Route 228
Route 229 (Bensville Road)
Route 231 (Prince Frederick Road)
Route 340
Route 355 (Rockville Pike)
Route 586 (Viers Mill Road)
Route 650 (New Hampshire Avenue)
Suitland Parkway
University Boulevard
US 1 (Rhode Island Avenue)

Major Interstate Connectors (continued)

US 15

US 29 (Colesville Road)

US 301 (Crain Highway)

Wisconsin Avenue

Bridges

Bay Bridge

9. Appendix B – Route Segments

Interstates

I-66

DC Line to Fairfax Drive
Fairfax Drive to I-495
I-495 to Route 50
Route 50 to Route 234

I-70

Frederick East to Baltimore
Frederick West to Pennsylvania State Line

I-95

Capital Beltway to Baltimore
Capital Beltway to US-50
US-50 to the Wilson Bridge
Wilson Bridge to the Mixing Bowl
Mixing Bowl to Lorton
Lorton to Dale Boulevard or Prince William Parkway (exit to Potomac Mill)
Dale Boulevard or Prince William Parkway (exit to Potomac Mill) to Route 234

I-270

Beltway to I-370
I-370 to Frederick

I-295 / DC-295

Pennsylvania Avenue North to US-50
US-50 North to Beltway
Pennsylvania Avenue South to Beltway

I-370

I-395

Southeast / Southwest Freeway
14th Street Bridge to Beltway

I-495

The Wilson Bridge to the Mixing Bowl

The Mixing Bowl to I-66

I-66 to the American Legion Bridge

The American Legion Bridge to I-95

I-95 to US 50

US 50 to the Wilson Bridge

Other Routes

Inside / Outside the Beltway

10. Appendix C – Summary of Available Content

Please see attached Microsoft Excel File entitled “Appendix C FINAL.xls”

11. Appendix D – Implementation Plan Scenarios Version 2

Based on the request of the Committee, we have described four scenarios relating to the development of 511 in the Washington, DC Metropolitan area. The scenarios are “No Build,” “Extension of 511 Virginia,” “Independent System” and “Part of Maryland Statewide System.” Each is described below with some of their advantages and disadvantages.

1. *No Build*

In this scenario, there will be no 511 system specifically for the Washington, DC Metropolitan area. Callers in Virginia will be able to access Virginia’s statewide 511 system and travelers in Maryland will be able to use the CHART web site for traffic information. People needing transit information will still be able to call their transit operators as they currently do.

Advantages:

- No cost
- Leaves options open for later deployment, if desired

Disadvantages:

- Unequal levels of 511 service in Washington, DC area (available in Virginia, not in DC or Maryland)
- Politicians / decision-makers might be concerned that Virginia residents can reach 511 but the rest of the area cannot
- 511 systems (as described by the FCC in the Report and Order) are supposed to cross jurisdictional boundaries and serve an entire metro area, not part

2. *Extension of 511 Virginia*

In this scenario, a Washington, DC 511 system would be built as an add-on to the 511 Virginia system, with the option in the future of either building an independent system based on CapCom and RITIS or remaining within the Virginia system. VDOT is making investments to serve Northern Virginia and additional funding from other stakeholders in the region would have to be agreed upon and could be based on population or another formula.

Advantages:

- Comparatively low cost for initial build (estimated resources required are \$430,000 – \$820,000 for development and build and \$315,000 – \$400,000 annually to operate)
- System could be built comparatively quickly with service launch in early- / mid-2006

- Allows for ultimate system to be built when the underlying institutional structures (CAPCOM) and data systems (RITIS) develop and become available

Disadvantages:

- At least at the outset, system functionality and structure will be defined by the 511 Virginia system
- If the system migrates to an independent system, some of the initial upfront costs used to modify the Virginia system will be lost
- Successful deployment depends on aligning with the Virginia contract period

The VDOT 511 contract currently expires in August 2007 and there are two 2-year extensions possible. To get the maximum benefit from this scenario, the decision to proceed would have to be made sooner rather than later.

3. *Independent System*

Under this scenario, the Washington, DC area would build its own 511 system in addition to the 511 service offered by Virginia.

Advantages:

- Provides the most flexibility for the specific needs of the region and the most robust system for the long-term
- Implementation does not depend on the success or timing of other contracts and projects

Disadvantages:

- More expensive than scenario 2 (resources required are estimated to be \$1,088,000 – \$2,465,000 for development and build and \$435,000 – \$585,000 annually to operate)
- Deployment will likely take at least six months to one year longer than scenario 2
- There is currently no institutional structure designed to lead this effort

4. *Part of Maryland Statewide System*

Under this scenario, the Washington, DC area would be served by the Maryland 511 system to complement the service offered by Virginia.

Advantages:

- Relative costs expected to be lower because of sharing of development costs with Maryland

- Flexible design to accommodate metropolitan area's travelers as this system has not been built or designed yet

Disadvantages:

- Maryland has no plans, as of publication, to build a 511 system
- Deployment will take longer than scenarios 2 and 3